

INTERNATIONAL ASSOCIATION OF ATHLETICS FEDERATIONS

COMPETITION RULES

2008

17, rue Princesse Florestine - BP 359
MC 98007 MONACO Cedex
+377 93 10 88 88 - Fax +377 93 15 95 15
<http://www.iaaf.org>

DEFINITIONS

Area

The geographical area comprising all of the Countries and Territories affiliated to one of the six Area Associations.

Area Association

An area association of the IAAF responsible for fostering Athletics in one of the six areas into which the Members are divided in the Constitution.

Athletics

Track and Field, Road Running, Race Walking, Cross-country Running and Mountain Running.

CAS

Court of Arbitration for Sport in Lausanne.

Citizen

A person who has legal citizenship of a Country or, in the case of a Territory, legal citizenship of the Territory's parent Country and appropriate legal status in the Territory under applicable laws.

Citizenship

Legal citizenship of a Country or, in the case of a Territory, legal citizenship of the Territory's parent Country and appropriate legal status in the Territory under applicable laws.

Club

A club or society of athletes affiliated to a Member in accordance with the rules of the Member.

Commission

A Commission of the IAAF that has been appointed by the Council under the terms of the Constitution.

Constitution

The IAAF Constitution.

Council

The IAAF Council.

Country

A self-governing geographical area of the world recognised as an

independent state by international law and international governmental bodies.

IAAF

The International Association of Athletics Federations.

International Invitation Meeting

Athletics competition in which athletes affiliated to two or more Members participate by invitation of the Meeting Organiser.

International Competition

Any of the International Competitions listed under Rule 1.1 of these Rules.

IOC

International Olympic Committee.

Member

A national governing body for Athletics affiliated to the IAAF.

Membership

Membership of the IAAF.

National Federation

The Member of the IAAF to which an athlete, athlete support personnel or other person under these Rules is affiliated.

Procedural Guidelines

The Procedural Guidelines for Doping Control as approved by the Council.

Regulations

The Regulations of the IAAF as may be passed by the Council from time to time.

Rules

The rules of competition of the IAAF as set out in this Competition Rules handbook.

Territory

A geographical territory or region which is not a Country, but which has certain aspects of self-government, at least to the extent of being autonomous in the control of its sport and which is thus recognised as such by the IAAF.

World Athletics Series

The major International Competitions in the IAAF's four-yearly official competition programme.

World Athletics Tour

An annual series of International Invitational Meetings in which athletes participate and can score points in accordance with Regulations approved by the Council. This series is organised by the IAAF.

World Combined Events Challenge

An annual series of Combined Events competitions in which athletes participate and can score points in accordance with Regulations approved by the Council. This series is organised by the IAAF.

World Race Walking Challenge

An annual series of Race Walking competitions in which athletes participate and can score points in accordance with Regulations approved by the Council. This series is organised by the IAAF.

Note 1: The above definitions apply to all Rules. There are further definitions in Chapter 3 which apply to the Anti-Doping Rules only.

Note 2: All references in the Rules to the masculine gender shall also include references to the feminine and all references to the singular shall also include references to the plural.

Note 3: Amendments (other than editorial amendments) to the corresponding Rules in the IAAF Competition Rules 2006 - 2007, approved by the 2007 Congress, are marked by double lines in the margin.

CHAPTER 1: INTERNATIONAL COMPETITIONS

RULE 1
International Competitions

1. The following are International Competitions:
 - (a) (i) Competitions included in the World Athletics Series.
(ii) The Athletics programme of the Olympic Games.
 - (b) The Athletics programme of Area, Regional or Group Games where the IAAF does not have exclusive control.
 - (c) Regional or Group Championships in Athletics not confined to participants from a single Area.
 - (d) Matches between teams from different Areas representing Member Federations or Areas or combinations thereof.
 - (e) (i) International Invitation Meetings which are included in the World Athletics Tour.
(ii) Competitions included in the Race Walking Challenge, the World Combined Events Challenge and any similar programmes approved by the Council.
 - (f) Area Championships and other intra-Area competitions organised by an Area Association.
 - (g) Regional or Group Championships in Athletics confined to participants from a single Area.
 - (h) Matches between teams representing two or more Members or combinations thereof within the same Area.
 - (i) International Invitation Meetings and competitions, other than those referred to in Rule 1.1(e), where appearance fees, prize money and/or the value of non-cash prizes exceed USD15,000 in total or USD5000 for any one event.
 - (j) Area programmes similar to those referred to in Rule 1.1(e).
2. The Rules shall apply as follows:
 - (a) The Eligibility Rules (Chapter 2), the rules governing Disputes (Chapter 4) and the Technical Rules (Chapter 5) shall apply to all International Competitions. Other international organisations recognised by the IAAF may have and enforce more restrictive eligibility requirements for competitions conducted under their jurisdiction.
 - (b) The Anti-Doping Rules (Chapter 3) shall apply to all International Competitions, except that, where the IOC, or

another international organisation recognised by the IAAF for such purpose, carries out doping control at a competition under their rules, such as the Olympic Games, those rules shall govern to the extent applicable.

- (c) The Advertising Rule (Rule 8) shall apply to all International Competitions listed in Rules 1.1(a)(i), (c), (d), and (e). Area Associations may promulgate their own advertising regulations to apply to the International Competitions listed in Rules 1.1(f), (g), (h), (i) and (j), failing which those of the IAAF shall apply.
- (d) Rules 2 to 7 shall apply to all International Competitions, except to the extent any Rule specifically limits its applicability.

RULE 2

Authorisation to Stage Competitions

1. The IAAF is responsible for supervising a global competition system in cooperation with the Area Associations. The IAAF shall coordinate its competition calendar and those of the respective Area Associations in order to avoid or minimise conflicts. All International Competitions must be authorised by the IAAF or an Area Association in accordance with this Rule 2. In the event that an Area Association fails properly to manage and control International Competitions in accordance with these Rules, the IAAF shall be entitled to intervene and take such steps as it deems necessary.
2. The IAAF alone shall have the right to organise the Athletics competition at the Olympic Games and the competitions that are included in the World Athletics Series.
3. The IAAF shall organise a World Championships in odd-numbered years.
4. Area Associations shall have the right to organise Area Championships and they may organise such other intra-Area events as they deem appropriate.

Competitions requiring an IAAF Permit

5. (a) An IAAF permit is required for all International Competitions listed in Rules 1.1(b), (c), (d) and (e).
 - (b) An application for a permit must be made to the IAAF by the Member in whose Country or Territory the International Competition is to take place not later than 12 months prior to

the competition, or such other deadline as may be established by the IAAF.

Competitions requiring an Area Association Permit

6. (a) An Area Association Permit is required for all International Competitions listed in Rules 1.1(g), (h), (i), and (j). Permits for International Invitation Meetings or competitions where appearance fees, prize money and/or the value of non-cash prizes exceed USD200,000 in total or USD25,000 in any one event shall not be issued prior to the Area Association's consultation with the IAAF regarding the date.
- (b) An application for a permit must be made to the appropriate Area Association by the Member in whose Country or Territory the International Competition is to take place not later than 12 months prior to the competition, or such other deadline as may be established by the Area Association.

Competitions authorised by a Member

7. Members may authorise national competitions, and foreign athletes may participate in those competitions, subject to Rules 4.2 and 4.3. If foreign athletes do participate, appearance fees, prize money, and/or non-cash prizes for all athletes at such national competitions shall not exceed USD15,000 in total or USD5000 for any one event. No athlete may participate in any such competition if he is ineligible to participate in the sport of Athletics under the rules of the IAAF, the host Member, or the National Federation to which he is affiliated.

RULE 3

Regulations Governing the Conduct of International Competitions

1. The Council may produce Regulations governing the conduct of International Competitions held under the Rules and regulating the relationships of athletes, athletes' representatives, meeting organisers and Members. These Regulations may be varied or amended by the Council as it sees fit.
2. The IAAF and Area Associations may designate one or more representatives to attend every International Competition requiring an IAAF or Area Association Permit respectively to ensure that the applicable Rules and Regulations are complied with. At the request of the IAAF or Area Association respectively, such representative(s) shall render a compliance

report within 30 days of the end of the International Competition in question.

RULE 4

Requirements to Compete in International Competitions

1. No athlete may take part in an International Competition unless he:
 - (a) is a member of a Club affiliated to a Member; or
 - (b) is himself affiliated to a Member; or
 - (c) has otherwise agreed to abide by the rules of a Member; and
 - (d) for International Competitions at which the IAAF is responsible for doping control (see Rule 35.7), has signed an agreement in a form set by the IAAF by which he agrees to be bound by the Rules, Regulations and Procedural Guidelines (as amended from time to time) and to submit all disputes he may have with the IAAF or a Member to arbitration only in accordance with these Rules, accepting not to refer any such disputes to any Court or authority which is not provided for in these Rules.
2. Members may require that no athlete or Club affiliated to the Member may take part in an athletics competition in a foreign Country or Territory without the Member's written approval. In such a case, no Member hosting a competition shall allow any foreign athlete or Club of the Member in question to take part without evidence of such permit certifying that the athlete or Club is eligible and permitted to compete in the Country or Territory concerned. Members shall notify the IAAF of all such permit requirements. To facilitate compliance with this Rule, the IAAF shall maintain on its web site a list of Members with such requirements.
3. No athlete may have affiliation abroad without previous authorisation from his National Federation of origin, if the Rules of that Federation require such authorisation. Even then, the National Federation of the Country or Territory in which the athlete is residing cannot enter any athlete's name for competitions in another Country or Territory without previous authorisation from the National Federation of origin. In all cases under this Rule, the National Federation of the Country or Territory in which the athlete is residing shall send a written request to the athlete's National Federation of origin, and the National Federation of origin shall send a written reply to that

request within thirty (30) days. Both of these communications shall be by a means that generates an acknowledgement of receipt. E-mail that includes a receipt function is acceptable for this purpose. If the response of the athlete's National Federation of origin is not received within the 30-day period, the authorisation shall be deemed to have been given.

In the event of a negative response to a request for authorisation under this Rule, which response must be supported by reasons, the athlete or the National Federation of the Country or Territory in which the athlete is residing may appeal against any such decision to the IAAF. The IAAF shall publish guidelines for the filing of an appeal under this Rule and these guidelines shall be available on the IAAF website. To facilitate compliance with this Rule, the IAAF shall maintain on its web site a list of National Federations with such authorisation requirements.

Note: Rule 4.3 concerns athletes aged 18 or over as at the 31st of December of the year in question. The Rule does not apply to athletes who are not Citizens of a Country or Territory or to political refugees.

RULE 5

Citizenship and Changes in Citizenship

1. In International Competitions under Rules 1.1(a) and (b), Members shall be represented only by Citizens of the Country or Territory which the affiliated Member represents.
2. Having once represented a Member in an International Competition under Rules 1.1(a) and (b), no athlete may thereafter represent another Member in an International Competition under Rules 1.1(a) and (b), except in the following circumstances:
 - (a) The incorporation of one Country or Territory in another.
 - (b) The creation of a new Country ratified by Treaty or otherwise recognised at international level.
 - (c) Acquisition of a new citizenship. In this case, the athlete shall not represent his new Member in an International Competition under Rules 1.1(a) and (b), for a period of three years following the date of acquisition of new Citizenship pursuant to the athlete's application. This period of three years may however be reduced or cancelled as set out below:
 - (i) the period may be reduced to 12 months with the agreement of the Members concerned. The reduction shall be effective upon receipt by the IAAF Office of a

- written notification of the Members' agreement;
 - (ii) the period may be reduced or cancelled in truly exceptional cases by the Council.
 - (d) Dual Citizenship: In this case, an athlete who holds Citizenship of two (or more) Countries or Territories, may represent the Member of either (or any) of them, as he may elect. However, having represented the Member in an International Competition under Rules 1.1(a) and (b), he shall not represent another Member of which he is a Citizen in an International Competition under Rules 1.1(a) and (b), for a period of three years from the date he last represented the first Member. This period of three years may be reduced or cancelled as set out below:
 - (i) the period may be reduced to 12 months with the agreement of the Members concerned. The reduction shall be effective upon receipt by the IAAF Office of a written notification of the Members' agreement which has been signed by both parties;
 - (ii) the period may be reduced or cancelled in truly exceptional cases with the approval of the Council.
3. (a) When a Citizen of a Country or Territory of a Member which is suspended from the IAAF is seeking to become a Citizen of a Country or Territory of a Member which is not suspended, he may compete in domestic competition organised by the Member which is not suspended on condition that:
- (i) he renounces his former nationality in the process of applying for citizenship of the Country or Territory of the Member which is not suspended and he publicly states this fact by advising the relevant Members concerned;
 - (ii) he completes at least one year's continuous residence in his new Country or Territory;
- (b) An athlete who has complied with the requirements of Rule 5.3(a) may compete in International Competitions under Rules 1.1(i) and (j) only after completing a period of two years' continuous residence in his new Country or Territory.
- (c) An athlete who has complied with the requirements of Rule 5.3(a) may represent his new National Federation in International Competitions under Rules 1.1(a) to (f) only after completing a period of three years' continuous

residence in his new Country or Territory and after he has acquired new citizenship.

- (d) The period(s) of continuous residence shall be computed on the basis of a year of 365 days, starting from the day after a person lands in the Country or Territory where he seeks to acquire new citizenship.
 - (e) In any continuous 365 day period, an athlete may not spend more than a total of 90 days in the foreign Country or Territory of the Member under suspension.
 - (f) An athlete seeking to qualify under this Rule must refrain from any athletics activities, which shall include, but not be restricted to, exhibition races, training, coaching, officiating, lecturing, giving interviews and publicity interviews, with any representatives of a Member which is under suspension.
4. Members and their officials, coaches and athletes are not to conduct any activities, as defined in Rule 5.3(f) or otherwise, associated with any representative of a suspended Member, its officials, coaches, judges, athletes, etc. In case of any infringement of this Rule, the provisions for suspensions and sanctions laid down in the Constitution shall apply.

RULE 6

Payments to Athletes

Athletics is an open sport and, subject to the Rules and Regulations, athletes may be paid in cash or in kind in any way appropriate for appearing, participating or performing in any athletics competition or engaging in any other commercial activity related to their participation in Athletics.

RULE 7

Athletes' Representatives

1. Members may allow athletes to use the services of an authorised Athletes' Representative to assist athletes, in co-operation with the Member, in the planning, arranging and negotiation of their athletics programme.
2. Members shall be responsible for the authorisation of Athletes' Representatives. Each Member shall have jurisdiction over Athletes' Representatives acting on behalf of their athletes and over Athletes' Representatives acting within their Country or Territory.
3. To assist Members in this task, the IAAF shall publish a

Guidance Note for Members on the regulation of National Federation/Athletes' Representatives. This Guidance Note shall contain a list of matters which should be included in each Member's system of regulation of Athletes' Representatives, the IAAF's suggestions of best practice in this area, as well as suggested forms of contract between the Athletes and their Representatives.

4. It is a condition of Membership that each Member includes in its constitution, provisions to ensure that no athlete will be granted the Member's consent to use an Athletes' Representative, and no Athletes' Representative shall be authorised, unless a written contract exists between the athlete and his Representative which contains the minimum terms set out in the IAAF Regulations concerning National Federation/Athletes' Representatives.
5. Any athlete who uses an unauthorised Athletes' Representative may be subject to sanctions in accordance with the Rules and Regulations.

RULE 8

Advertising and Displays during International Competitions

1. Advertising and displays of a promotional nature shall be permitted in all International Competitions as specified in Rule 1.2(c), provided such advertising and displays comply with the terms of this Rule and with any Regulations that may be passed hereunder.
2. The Council may pass Regulations from time to time giving detailed guidance as to the form advertising may take and the manner in which promotional or other material may be displayed at International Competitions conducted under these Rules. These Regulations shall adhere to at least the following principles:
 - (a) Only advertising of a commercial or charitable nature shall be allowed at competitions conducted under these Rules. No advertising which has as its objective the advancement of any political cause or the interests of any pressure group, whether domestic or international, shall be allowed.
 - (b) No advertising may appear which, in the opinion of the IAAF, is tasteless, distracting, offensive, defamatory or unsuitable bearing in mind the nature of the event. No advertising may appear which obscures, either partially or otherwise, the television camera's view of a competition. All advertising must comply with any applicable safety regulations.

- (c) The advertising of tobacco products is prohibited. The advertising of alcohol products is prohibited, unless expressly permitted by the Council.
3. The Regulations under this Rule may be amended by the Council at any time.

CHAPTER 2: ELIGIBILITY

RULE 20**Definition of Eligible Athlete**

An athlete is eligible to compete if he agrees to abide by the Rules and has not been declared ineligible.

RULE 21**Restriction of Competition to Eligible Athletes**

1. Competition under these Rules is restricted to athletes who are under the jurisdiction of a Member and who are eligible to compete under the Rules.
2. In any competition under the Rules, the eligibility of an athlete competing shall be guaranteed by the Member to which the athlete is affiliated.
3. The eligibility rules of Members shall be strictly in conformity with those of the IAAF and no Member may pass, promulgate or retain in its constitution or regulations any eligibility rule or regulation which is in direct conflict with a Rule or Regulation. Where there is a conflict between the eligibility rules of the IAAF and the eligibility rules of a Member, the eligibility rules of the IAAF shall apply.

RULE 22**Ineligibility for International and Domestic Competitions**

1. The following persons may be declared ineligible for competitions, whether held under these Rules or the domestic rules of a Member.
Any person:
 - (a) whose National Federation is currently suspended by the IAAF. This does not apply to domestic competitions organised by the currently suspended Member for the Citizens of that Country or Territory;
 - (b) who has taken part in any athletics competition or event in which any of the competitors were, to his knowledge, suspended from participation or ineligible to compete under the Rules, or which takes place in the Country or Territory of a suspended Member. This does not apply to any athletics

- competition which is restricted to the Masters' age group (35 years and over);
- (c) who takes part in any athletics competition which is not sanctioned, recognised or certified by the Member in the Country or Territory in which the competition is held;
 - (d) who is suspended from participation in or ineligible to compete in competitions under the jurisdiction of his National Federation, in so far as such ineligibility is consistent with these Rules;
 - (e) who contravenes the Anti-Doping Rules (see Chapter 3);
 - (f) who has committed any act or made any statement either verbally or in writing, or has been responsible for any breaches of the Rules or other conduct which is considered to be insulting or improper or likely to bring the sport into disrepute;
 - (g) who contravenes Rule 8 (Advertising and Displays during International Competitions) or any Regulations made thereunder;
 - (h) who uses the services of an Athletes' Representative other than one approved by the relevant Member under Rule 7;
 - (i) who has been declared ineligible by virtue of a breach of any Regulations made under the Rules.
2. In the event of an alleged breach of this Rule, the disciplinary procedures to be followed in determining an athlete's ineligibility (other than in a case of a breach of Rule 22.1(e)) are set out in Rule 60.4.
 3. If an athlete competes whilst suspended or ineligible, the period of his ineligibility shall, unless otherwise stated in the relevant Rule, recommence from the time he last competed as though no part of a period of suspension or ineligibility had been served.

CHAPTER 3: ANTI-DOPING

DEFINITIONS

Adverse Analytical Finding

A report from a laboratory or other approved testing entity that identifies in a sample the presence of a prohibited substance or its metabolites or markers or evidence of the use of a prohibited method.

Athlete Support Personnel

Any coach, trainer, manager, authorised athlete representative, agent, team staff, official, medical or para-medical personnel or any other person working with, or treating athletes participating in, or preparing for, competition in Athletics.

Attempt

Purposely engaging in conduct that constitutes a substantial step in a course of conduct planned to culminate in the commission of an Anti-Doping Rule violation.

Code

The World Anti-Doping Code.

Competition

An event or series of events held over one or more days (e.g., the World Championships, the World Athletics Final or an individual Golden League meeting).

Event

A single race or contest in a competition (e.g. the 100m or the Javelin Throw).

In-competition Testing

In-competition testing means testing where an athlete is selected for testing in connection with a specific event.

International-Level athlete

For the purposes of the Anti-Doping Rules (Chapter 3) and Disputes (Chapter 4), an athlete who is in the Registered Testing Pool for out-of-competition testing or who is competing in an International Competition under Rule 35.7.

International Standard

A standard adopted by WADA in support of the Code.

Marker

A compound, group of compounds or biological parameters that indicates the use of a prohibited substance or prohibited method.

Metabolite

Any substance produced by a biotransformation process.

National Anti-Doping Organisation

The entity designated by each Country or Territory as possessing the primary authority and responsibility to adopt and implement anti-doping rules, direct the collection of doping control samples, the management of test results, and the conduct of hearings, all at the national level.

No Fault or No Negligence

When exceptional circumstances have been determined in an athlete's case under Rule 38 to demonstrate that the athlete did not know or suspect, and could not reasonably have known or suspected even with the exercise of utmost caution, that he had used or been administered a prohibited substance or prohibited method.

No Significant Fault or No Significant Negligence

When exceptional circumstances have been determined in an athlete's case under Rule 38 to demonstrate that the athlete's fault or negligence, when viewed in the totality of the circumstances, was not significant in relationship to the Anti-Doping Rule violation.

Out-of-competition testing

Out-of-competition testing means any doping control which is not in-competition.

Possession

The actual, physical possession or the constructive possession (which shall be found only if the person has exclusive control over the prohibited substance/method or the premises in which a prohibited substance/method exists) of a prohibited substance or prohibited method; provided, however, that if the person does not have exclusive control over the prohibited substance/method or the premises in which a prohibited substance/method exists, constructive possession shall only be found if the person knew about the presence of the prohibited substance/method and intended to exercise control over it.

Prohibited List

The Prohibited List published by WADA identifying the prohibited substances and prohibited methods.

Prohibited Method

Any method so described on the Prohibited List.

Prohibited Substance

Any substance so described on the Prohibited List.

Registered Testing Pool

The pool of top-ranked athletes established by the IAAF who are subject to both in-competition and out-of-competition testing as part of the IAAF's testing programme.

Sample / Specimen

Any biological material collected for the purposes of doping control.

Tampering

The altering of any item for an improper purpose or in an improper way in relation to doping control, bringing improper influence to bear upon the doping control or disciplinary process, or interfering to alter results or to prevent normal procedures from occurring.

Target Testing

The selection of athletes for testing where specific athletes or groups of athletes are selected on a non-random basis for testing at a specified time.

TUE

Therapeutic Use Exemption.

Trafficking

The selling, transporting, sending, delivering or distributing of a prohibited substance or prohibited method to an athlete, athlete support personnel or other person, either directly or through one or more third parties, but excluding the selling or distributing (by medical personnel or other persons) of a prohibited substance or prohibited method for genuine and legal therapeutic purposes.

Use

The application, ingestion, injection or consumption by any means whatsoever of any prohibited substance or prohibited method.

WADA

The World Anti-Doping Agency.

RULE 30

Scope of the Anti-Doping Rules

1. These Anti-Doping Rules shall apply to the IAAF, its Members and Area Associations and to athletes, athlete support personnel and other persons who participate in the IAAF, its Members and Area Associations by virtue of their agreement, membership, affiliation, authorisation, accreditation or participation in their activities or competitions.
2. All Members and Area Associations shall comply with these Anti-Doping Rules and the Procedural Guidelines. These Anti-Doping Rules and the Procedural Guidelines shall be incorporated either directly, or by reference, into the rules of each Member and Area Association and each Member and Area Association shall include in its rules the procedural regulations necessary to implement the Anti-Doping Rules and the Procedural Guidelines effectively (and any changes that may be made to them). The rules of each Member and Area Association shall specifically provide that all athletes, athlete support personnel and other persons under the jurisdiction of the Member or Area Association shall be bound by these Anti-Doping Rules and the Procedural Guidelines.
3. These Anti-Doping Rules and the Procedural Guidelines shall apply to all doping controls over which the IAAF and respectively its Members and Area Associations have jurisdiction.
4. The IAAF shall focus its testing under these Anti-Doping Rules on International-Level athletes and on athletes who compete, or who are preparing to compete, in International Competitions.
5. In order to be eligible to compete or participate in, or otherwise be accredited at, an International Competition, athletes (and where applicable) athlete support personnel and other persons must have signed a prior written acknowledgment and agreement to these Anti-Doping Rules and the Procedural Guidelines, in a form to be decided by the Council. In guaranteeing the eligibility of its athletes for International Competition (see Rule 21.2), Members guarantee that the athletes have signed a written acknowledgement and agreement in the required form and that a copy of the signed agreement has been sent to the IAAF Office.
6. It is the responsibility of each Member to ensure that all national level testing on its athletes and the management of results from such testing complies with these Anti-Doping Rules and the

Procedural Guidelines. It is recognised that, in some Countries, the Member will conduct the testing and result management process itself whilst, in others, some or all of the Member's responsibilities may be delegated or assigned (either by the Member itself or under applicable national legislation or regulation) to a national anti-doping organisation or other third party. In respect of these Countries, reference in these Anti-Doping Rules to the Member or National Federation (or its relevant officers) shall, where applicable, be a reference to the national anti-doping organisation or other third party (or its relevant officers).

7. Notice under these Anti-Doping Rules to an athlete, athlete support personnel or other person who is under the jurisdiction of a Member may be accomplished by delivery of the notice to the Member concerned. The Member shall be responsible for making immediate contact with the person to whom the notice is applicable.

RULE 31

IAAF Anti-Doping Organisation

1. The IAAF shall principally act under these Anti-Doping Rules by the following person(s) or bodies:
 - (a) the Council (see Rules 31.2-3);
 - (b) the Medical and Anti-Doping Commission (see Rules 31.4-7);
 - (c) the Doping Review Board (see Rules 31.8-10); and
 - (d) the IAAF Anti-Doping Administrator (see Rules 31.11-13).

The Council

2. The Council has a duty to the IAAF Congress to oversee and supervise the activities of the IAAF in accordance with its Objects (see Article 6.12(a) of the Constitution). One of these Objects is to promote fair play in sport, in particular, to play a leading role in the fight against doping, both within Athletics and externally in the wider sporting community, and to develop and maintain programmes of detection, deterrence and education which are aimed at the eradication of the scourge of doping within sport (see Article 3.8 of the Constitution).
3. The Council has the following powers under the Constitution in overseeing and supervising the activities of the IAAF:
 - (a) to establish any Commission or sub-Commission, whether on an ad hoc or permanent basis, that it deems to be

necessary for the proper functioning of the IAAF (see Article 6.11(j) of the Constitution).

- (b) to make any interim amendments to the Rules it considers to be necessary between Congresses and to fix a date on which such amendments shall take effect. The interim amendments shall be reported to the next Congress, which shall decide whether they shall be made permanent (see Article 6.11(c) of the Constitution).
- (c) to approve, reject or amend the Procedural Guidelines (see Article 6.11(i) of the Constitution); and
- (d) to suspend or take other sanctions against a Member for a breach of the Rules in accordance with the provisions of Article 14.7 (see Article 6.11(b) of the Constitution).

The Medical and Anti-Doping Commission

- 4. The Medical and Anti-Doping Commission is appointed as a Commission of the Council under Article 6.11(j) of the Constitution to provide the IAAF with general advice on all anti-doping and related matters, including in relation to these Anti-Doping Rules and the Procedural Guidelines.
- 5. The Medical and Anti-Doping Commission shall consist of up to 15 members who shall meet at least once a year, normally at the end of each calendar year, in order to review the IAAF's anti-doping activities in the preceding 12 months and to establish, for the approval of the Council, the IAAF's anti-doping programme for the year ahead. The Medical and Anti-Doping Commission shall also consult on a regular basis throughout the course of the year, as the need may arise.
- 6. The Medical and Anti-Doping Commission shall have responsibility for the following further specific tasks under these Anti-Doping Rules:
 - (a) publishing the Procedural Guidelines, and amendments to the Procedural Guidelines, as often as may be required. The Procedural Guidelines shall comprise, either directly or by reference, the following documents issued by WADA:
 - (i) the Prohibited List;
 - (ii) the International Standard for Testing;
 - (iii) the International Standard for Laboratories; and
 - (iv) the International Standard for Therapeutic Use Exemptions
 together with any additions or modifications to such documents, or further procedures or guidelines, that may be

deemed necessary to comply with these Anti-Doping Rules or otherwise pursue the IAAF's anti-doping programme.

The Procedural Guidelines, and any proposed amendment to them, unless otherwise stated in these Anti-Doping Rules, must be approved by the Council. Upon giving its approval, the Council shall fix a date on which the Procedural Guidelines, or any proposed amendment to them, shall take effect. The IAAF Office shall notify the Members of this date and shall publish the Procedural Guidelines, and any proposed amendment to them, on the IAAF website.

- (b) advising the Council on amendments to these Anti-Doping Rules as may be necessary from time to time. Any proposed amendment to be made to the Anti-Doping Rules between Congresses must be approved by the Council and notified to the Members in accordance with Article 6.11(c) of the Constitution.
- (c) planning, implementing and monitoring anti-doping information and anti-doping education programmes. These programmes should provide updated and accurate information on at least the following issues:
 - (i) prohibited substances and prohibited methods in the Prohibited List;
 - (ii) health consequences of doping;
 - (iii) doping control procedures; and
 - (iv) athletes' rights and responsibilities.
- (d) granting TUEs in accordance with Rule 34.5(a).
- (e) establishing general guidelines for the selection of athletes in the Registered Testing Pool.

The Medical and Anti-Doping Commission may, in the course of exercising any of the above tasks, call upon experts to provide further specialist medical or scientific advice as may be required.

- 7. The Medical and Anti-Doping Commission shall report to the Council on its activities before each Council meeting. It shall communicate with the IAAF Office on all anti-doping and related matters through the IAAF Medical and Anti-Doping Department.

The Doping Review Board

- 8. The Doping Review Board is appointed as a sub-Commission of the Council under Article 6.11(j) of the Constitution with at least the following specific tasks:
 - (a) to determine on behalf of the Council whether exceptional circumstances exist in cases which are referred to it under

Rule 38.16;

- (b) to decide whether cases should be referred to arbitration before CAS under Rule 60.23 and whether, in such cases, to re-impose the athlete's suspension pending the CAS decision; and
- (c) to decide in cases which are referred to it under Rule 43.3 whether the results of doping controls carried out by a sporting body other than the IAAF, under rules and procedures which are different to those of the IAAF, should be recognised by the IAAF.

The Doping Review Board may, in the course of exercising any of the above tasks, refer to the Medical and Anti-Doping Commission or the Council for its opinion or guidance in relation to a particular case or to the Council on any matter of general policy that may have arisen.

- 9. The Doping Review Board shall consist of three persons, one of whom shall be legally qualified. The President shall have authority at any time to appoint an additional person or persons to the Doping Review Board, as may be required, on a temporary basis.
- 10. The Doping Review Board shall report to the Council on its activities before each Council meeting.

The IAAF Anti-Doping Administrator

- 11. The IAAF Anti-Doping Administrator is the head of the IAAF's Medical and Anti-Doping Department. He shall have responsibility for implementing the anti-doping programme which has been established by the Medical and Anti-Doping Commission under Rule 31.5. He shall report to the Medical and Anti-Doping Commission in this regard at least once a year at the time of the Medical and Anti-Doping Commission's annual meeting and, more regularly, if called upon to do so.
- 12. The IAAF Anti-Doping Administrator shall have responsibility for the day to day administration of doping cases arising under these Anti-Doping Rules. In particular, the IAAF Anti-Doping Administrator shall be the person responsible, where applicable, for conducting the results management process in accordance with Rule 37 and for deciding upon the provisional suspension of athletes in accordance with Rule 38.
- 13. The IAAF Anti-Doping Administrator may at any time in the course of his work seek an advisory opinion from the Chairperson of the Medical and Anti-Doping Commission, from the Doping

Review Board or from such other person as he considers to be appropriate.

RULE 32

Anti-Doping Rule Violations

1. Doping is strictly forbidden under these Anti-Doping Rules.
2. Doping is defined as the occurrence of one or more of the following Anti-Doping Rule violations:
 - (a) the presence of a prohibited substance or its metabolites or markers in an athlete's body tissues or fluids.

All references to a prohibited substance in these Anti-Doping Rules and the Procedural Guidelines shall include a reference, where applicable, to its metabolites or markers.

 - (i) it is each athlete's personal duty to ensure that no prohibited substance enters his body tissues or fluids. Athletes are warned that they are responsible for any prohibited substance found to be present in their bodies. It is not necessary that intent, fault, negligence or knowing use on an athlete's part be demonstrated in order to establish an Anti-Doping Rule violation under Rule 32.2(a).
 - (ii) except those prohibited substances for which a reporting threshold is specifically identified in the Prohibited List, the detected presence of any quantity of a prohibited substance in an athlete's sample shall constitute an Anti-Doping Rule violation.
 - (iii) as an exception to the general application of Rule 32.2(a), the Prohibited List may establish specific criteria for the evaluation of prohibited substances that can also be produced endogenously.
 - (b) the use or attempted use of a prohibited substance or prohibited method.
 - (i) the success or failure of the use of a prohibited substance or prohibited method is immaterial. It is sufficient that the prohibited substance or prohibited method is used, or attempted to be used, for an Anti-Doping Rule violation to be committed.
 - (ii) an admission of use or attempted use of a prohibited substance or a prohibited method may be made either orally in a verifiable manner or in writing. A statement shall not however be admissible where it is made more than eight years after the facts to which it relates.

- (c) the refusal or failure, without compelling justification, to submit to doping control having been requested to do so by a responsible official or otherwise seeking to evade doping control.
- (d) the evaluation of three missed out-of-competition tests (as defined in Rule 35.17) in any period of five years beginning with the date of the first missed test.

Note: If an athlete has a missed test as a result of a whereabouts violation or an unsuccessful test attempt made prior to 1 November 2005, the 18-month period provided for in Rule 32.2(d) of the 2004-2005 Competition Rules remains in effect. The 5-year period applies only when all three missed tests are as a result of whereabouts violations or unsuccessful test attempts made on or after 1 November 2005.

- (e) tampering, or attempting to tamper, with any part of the doping control process or its related disciplinary procedures.
- (f) the possession of a prohibited substance or prohibited method.
 - (i) possession by an athlete means possession at any time or place of a substance that is prohibited out-of-competition or a prohibited method unless the athlete establishes that the possession is pursuant to a TUE granted in accordance with Rule 34.5 or some other acceptable justification.
 - (ii) possession by athlete support personnel means possession of a substance that is prohibited out-of-competition or a prohibited method in connection with an athlete, competition or training, unless the athlete support personnel establishes that the possession is pursuant to a TUE granted to an athlete in accordance with Rule 34.5 or some other acceptable justification.
- (g) trafficking in a prohibited substance or prohibited method.
- (h) the administration, or attempted administration, of a prohibited substance or prohibited method to an athlete or assisting, encouraging, aiding, abetting, covering up or engaging in any other type of complicity involving an Anti-Doping Rule violation or attempted violation.
- (i) competing, or attempting to compete, whilst provisionally suspended or ineligible under these Anti-Doping Rules.

RULE 33

Standards of Proof of Doping

1. The IAAF, the Member or other prosecuting authority shall have the burden of establishing that an Anti-Doping Rule violation has occurred under these Anti-Doping Rules.
2. The standard of proof shall be whether the IAAF, the Member or other prosecuting authority has established an anti-doping rule violation to the comfortable satisfaction of the relevant hearing body, bearing in mind the seriousness of the allegation which is made. This standard of proof is greater than a mere balance of probability but less than proof beyond a reasonable doubt.
3. Where these Anti-Doping Rules place the burden of proof on an athlete, athlete support personnel or other person alleged to have committed an anti-doping violation to rebut a presumption or establish specified facts or circumstances, the standard of proof shall be by a balance of probability.
4. Facts related to Anti-Doping Rule violations may be established by any reliable means. The following standards of proof shall be applicable in doping cases:
 - (a) WADA-accredited laboratories are presumed to have conducted sample analysis and custodial procedures in accordance with the International Standard for Laboratories. The athlete may rebut this presumption by establishing that a departure from the International Standard for Laboratories has occurred, in which case the IAAF, the Member or other prosecuting authority shall have the burden of establishing that such departure did not undermine the validity of the adverse analytical finding.
 - (b) A departure from the International Standard for Testing (or other applicable provision in the Procedural Guidelines) shall not invalidate a finding that a prohibited substance was present in a sample or that a prohibited method was used, or that any other Anti-Doping Rule violation under these Anti-Doping Rules was committed, unless the departure was such as to undermine the validity of the finding in question. If the athlete establishes that a departure from the International Standard for Testing (or other applicable provision in the Procedural Guidelines) has occurred, then the IAAF, the Member or other prosecuting authority shall have the burden of establishing that such departure did not undermine the validity of the finding that a prohibited substance was

present in a sample, or that a prohibited method was used, or the factual basis for establishing any other Anti-Doping Rule violation was committed under these Anti-Doping Rules.

RULE 34

The Prohibited List

1. These Anti-Doping Rules incorporate the Prohibited List which shall be published and revised by WADA.
2. The IAAF will make the current Prohibited List available to each Member and it shall be available on the IAAF website. Each Member shall in turn ensure that the current Prohibited List is made available (either on its website or otherwise) to all athletes, athlete support personnel and any other relevant persons under its jurisdiction.
3. Unless otherwise stated in the Prohibited List and/or any revision to the Prohibited List, the Prohibited List and revisions shall go into effect under these Anti-Doping Rules three months after publication of the Prohibited List by WADA without requiring any further action by the IAAF. The IAAF may also request that WADA include additional substances or methods which have the potential for abuse in Athletics, as part of the WADA monitoring programme.
4. WADA's determination of the prohibited substances and prohibited methods that will be included on the Prohibited List shall be final and shall not be subject to legal challenge by any athlete or other person.
5. Athletes with a documented medical condition requiring the use of a prohibited substance or a prohibited method must first obtain a TUE. TUEs will however be granted only in cases of clear and compelling clinical need where no competitive advantage can be gained by the athlete.
 - (a) International-Level athletes must obtain a TUE from the IAAF prior to participating (regardless of whether the athlete has previously obtained a TUE at national level). Athletes seeking a TUE should make a written request to the Medical and Anti-Doping Commission. Details of the procedure for the application shall be found in the Procedural Guidelines. TUEs granted by the IAAF under this Rule shall be reported to the athlete's National Federation and to WADA.
 - (b) Non-International-Level athletes must obtain a TUE from their National Federation, or from such other body as may be designated by their National Federation to grant TUEs, or

which otherwise has competent authority to grant TUEs in the Country or Territory of the National Federation. National Federations shall in all cases be responsible for reporting promptly the grant of any TUEs under this Rule to the IAAF and to WADA.

RULE 35

Testing

1. Every athlete under these Anti-Doping Rules may be subject to in-competition testing at the competitions at which he competes and to out-of-competition testing at any time or place. Athletes shall submit to doping control whenever requested to do so by a responsible official.
2. It is a condition of Membership of the IAAF that each Member (and respectively Area Association) includes within its constitution:
 - (a) a provision giving the Member (and respectively the Area Association) authority to conduct in and out-of-competition doping controls, a report of which, in the case of the Member, must be submitted to the IAAF on an annual basis (see Rule 41.4);
 - (b) a provision giving the IAAF authority to conduct doping controls at the Member's National Championships (and respectively at the Area Association's Area Championships);
 - (c) a provision giving the IAAF authority to conduct unannounced out-of-competition testing on the Member's athletes; and
 - (d) a provision making it a condition of membership or affiliation to its National Federation, and a condition of participation in competitions which are sanctioned or organised by the Member, that its athletes agree to be subject to any in-competition and out-of-competition testing carried out by the Member, the IAAF and any other body with competent authority to test under these Anti-Doping Rules.
3. The IAAF and its Members may delegate testing under this Rule to any Member, other Member, WADA, governmental agency, national anti-doping organisation or other third party which they deem to be suitably qualified for the purpose.
4. In addition to testing by the IAAF and its Members (and by entities to which the IAAF and its Members may have delegated their testing responsibility under Rule 35.3), athletes may be subject to testing:

- (a) in-competition by any other organisation or body which has competent authority to conduct testing at the competition in which they are participating; and
- (b) out-of-competition by
 - (i) WADA;
 - (ii) the national anti-doping organisation of the Country or Territory in which they are present; or
 - (iii) by, or on behalf of, the IOC in connection with the Olympic Games.

However, only a single organisation shall be responsible for initiating and directing testing during a competition. At International Competitions, the collection of samples shall be initiated and directed by the IAAF (see Rule 35.7) or other international sports organisation ruling body in the case of an International Competition over which the IAAF has no exclusive control (e.g. the IOC at the Olympic Games or the Commonwealth Games Federation at the Commonwealth Games). If the IAAF or such other international sports organisation ruling body decides not to conduct testing at an International Competition, the national anti-doping organisation in the Country or Territory where the International Competition is to take place may, with the approval of the IAAF and WADA, initiate and conduct such testing.

- 5. The IAAF and its Members shall promptly report all completed in-competition tests through the WADA clearinghouse (in the case of reporting by a Member, with a copy of such report being sent to the IAAF at the same time) in order to avoid any unnecessary duplication in testing.
- 6. Testing conducted by the IAAF and its Members under this Rule shall be in substantial conformity with the International Standard for Testing (and other applicable provisions in the Procedural Guidelines) in force at the time of testing.

In-competition testing

- 7. The IAAF shall have responsibility for initiating and directing in-competition testing at the following International Competitions:-
 - (a) World Championships;
 - (b) World Athletics Series Competitions;
 - (c) Golden League, Super Grand Prix, Grand Prix, Grand Prix II Meetings;
 - (d) IAAF Permit Meetings; and
 - (e) at such other International Competitions as the Council may

- determine on the recommendation of the Medical and Anti-Doping Commission.
8. The Council shall determine the anticipated number of athletes to be tested at the above International Competitions on the recommendation of the Medical and Anti-Doping Commission. Athletes to be tested shall be selected as follows:
 - (a) on a final position basis and/or random basis;
 - (b) at the discretion of the IAAF (acting by its relevant official or body), by any method that it shall choose, including target testing;
 - (c) any athlete who has broken or equalled an Area and/or World Record.
 9. If the IAAF has delegated testing under Rule 35.3, it may appoint a representative to attend at the International Competition in question to ensure that these Anti-Doping Rules and the Procedural Guidelines are being properly applied.
 10. In consultation with the relevant Member (and respectively with the relevant Area Association), the IAAF may conduct, or assist in the conduct of, doping controls at a Member's National Championships or Area Association's Area Championships.
 11. In all other cases (except where doping control is carried out under the rules of another international sports organisation ruling body, for example, by the IOC at the Olympic Games), the Member conducting the controls, or in whose Country or Territory a competition is held, shall be responsible for initiating and directing in-competition testing. If the Member has delegated its testing under Rule 35.3, it is the Member's responsibility to ensure that such testing carried out in its Country or Territory complies with these Anti-Doping Rules and the Procedural Guidelines.

Out-of-competition Testing

12. The IAAF shall focus its out-of-competition testing primarily on International-Level athletes. However, it may, at its discretion, conduct out-of-competition testing on any athlete at any time. In most cases, testing shall be carried out without notice to the athlete or his athlete support personnel or National Federation.
13. It is the duty of every Member, officer of a Member and other person under the jurisdiction of a Member to assist the IAAF (and, if appropriate, another Member, WADA or other body with competent testing authority) in the conduct of out-of-competition testing under this Rule. Any Member, officer of a Member or

other person under the jurisdiction of a Member preventing, hindering, obstructing or otherwise tampering with the conduct of such testing may be liable to sanction under these Anti-Doping Rules.

14. Out-of-competition testing shall be conducted under these Anti-Doping Rules in respect of the substances and methods prohibited out-of-competition in the Prohibited List.
15. Statistics of out-of-competition testing shall be published once a year per athlete in the Registered Testing Pool and per Member Federation.

Whereabouts information / Missed tests

16. At the request of the IAAF, athletes in the Registered Testing Pool shall be required to provide the IAAF with whereabouts information adequate for the purposes of out-of-competition testing on those athletes. Athletes shall be required to keep their whereabouts information on file on a quarterly basis and shall be required to notify the IAAF immediately that there is any change to such information to ensure that it is kept current at all times. The ultimate responsibility for providing whereabouts information rests with each athlete. An athlete's National Federation shall, however, use its best efforts to assist the IAAF in obtaining whereabouts information for the athlete, if so requested by the IAAF. Whereabouts information provided by an athlete pursuant to this Rule shall, where appropriate, be shared with WADA and any other body having competent authority to test the athlete, on the strict condition that such information be used solely for doping control purposes.
17. If an athlete fails on request to provide the IAAF with his whereabouts information, or to provide adequate whereabouts information, or is unable to be located for testing by a doping control officer at the whereabouts retained on file for that athlete, he shall be subject to an evaluation by the IAAF Anti-Doping Administrator for a missed test. If, as a result of such evaluation, the IAAF Anti-Doping Administrator concludes that the athlete has failed in his obligation to provide whereabouts information or adequate whereabouts information, the IAAF Anti-Doping Administrator shall evaluate the failure as a missed test and the athlete shall be so notified in writing. If an athlete is evaluated as having three missed tests in any period of five years beginning with the date of the first missed test, he shall have committed an Anti-Doping Rule violation in accordance with Rule 32.2(d).

Return to competition following retirement or other period of non-competition

18. If an athlete, who has been requested to keep his whereabouts on file, no longer wishes to be subject to out-of-competition testing on account of the fact that he has retired, or has chosen not to compete for any other reason, he shall be required to give notice to the IAAF in the prescribed form. The same athlete may not then resume competition unless he has given the IAAF 12 months notice in the prescribed form of his intention to return to competition and has made himself available for out-of-competition testing by the IAAF in that period by providing the IAAF with whereabouts information pursuant to Rule 35.16. An athlete who refuses or fails to submit to doping control on account of the fact that he has retired or has chosen not to compete for any other reason, but who has not provided the IAAF with notice under this Rule, shall have committed an Anti-Doping Rule violation in accordance with Rule 32.2(c).

RULE 36

Analysis of Samples

1. All samples collected under these Anti-Doping Rules shall be analysed in accordance with the following general principles:

Use of Approved Laboratories

- (a) Samples for analysis shall be sent only to WADA-accredited laboratories or as otherwise approved by WADA. In the case of IAAF tests, samples shall be sent only to WADA-accredited laboratories (or, where applicable, to haematological laboratories or mobile testing units) which are approved by the IAAF.

Substances subject to detection

- (b) Samples shall be analysed to detect prohibited substances and prohibited methods on the Prohibited List and such other substances as may be directed by WADA pursuant to its monitoring programme.

Research on samples

- (c) No sample may be used for any purpose other than the detection of prohibited substances (or classes of prohibited substances) or prohibited methods on the Prohibited List, or as otherwise directed by WADA pursuant to its monitoring programme, without the athlete's written consent.

International Standard for Laboratories

- (d) Laboratories shall analyse samples and report results in conformity with the International Standard for Laboratories.
2. All samples provided by athletes in doping controls conducted under the responsibility of the IAAF shall immediately become the property of the IAAF.
 3. If, at any stage, any question or issue arises concerning the analysis or interpretation of the results of a sample, the person responsible for the analysis at the laboratory (or haematological laboratory or mobile testing unit) may consult the IAAF Anti-Doping Administrator for guidance.
 4. If, at any stage, any question or issue arises in relation to a sample, the laboratory (or mobile testing unit) may conduct any further or other tests necessary to clarify the question or issue so raised and such tests may be relied upon by the IAAF when deciding whether a sample has given rise to an adverse analytical finding.
 5. Where an analysis indicates the presence of a prohibited substance or the use of a prohibited substance or prohibited method, the WADA-accredited laboratory shall immediately confirm the adverse analytical finding in writing, either to the IAAF, in the case of an IAAF test, or to the relevant Member in the case of a national test (with a copy to the IAAF). In the case of a national test, the Member shall inform the IAAF of the adverse analytical finding and the name of the athlete promptly on receipt of the information from the WADA-accredited laboratory and, in all circumstances, within two weeks of such receipt.

RULE 37**Results Management**

1. Following notification of an adverse analytical finding or other Anti-Doping Rule violation under these Anti-Doping Rules, the matter shall be subject to the results management process set out below.
2. In the case of an International-Level athlete, the results management process shall be conducted by the IAAF Anti-Doping Administrator and, in all other cases, it shall be conducted by the relevant person or body of the athlete's National Federation. The relevant person or body of the athlete's National Federation shall keep the IAAF Anti-Doping Administrator updated on the process at all times. Requests for assistance or

information in conducting the results management process may be made to the IAAF Anti-Doping Administrator at any time.

For the purposes of this Rule and of Rule 38, references hereafter to the IAAF Anti-Doping Administrator shall, where applicable, be references to the relevant person or body of the Member and references to an athlete shall, where applicable, be references to any athlete support personnel or other person.

3. On notification of an adverse analytical finding, the IAAF Anti-Doping Administrator shall conduct a review to determine whether:
 - (a) an applicable TUE has been granted to the athlete for the prohibited substance; or
 - (b) there is any apparent departure (or departures) from the International Standard for Testing (or other applicable provision in the Procedural Guidelines) or the International Standard for Laboratories such as to undermine the validity of the finding.
4. If the initial review under Rule 37.3 does not reveal an applicable TUE or departure or departures from the International Standard for Testing (or other applicable provision in the Procedural Guidelines) or the International Standard for Laboratories such as to undermine the validity of the finding, the IAAF Anti-Doping Administrator shall promptly notify the athlete of:
 - (a) the adverse analytical finding;
 - (b) the anti-doping violation rule that has been breached or, in a case falling under Rule 37.5, a description of the additional investigation to be conducted to determine whether an anti-doping rule violation has occurred;
 - (c) the time limit within which the athlete is to provide the IAAF, either directly or through his National Federation, with an explanation for the adverse analytical finding;
 - (d) the athlete's right to request promptly for the analysis of the "B" sample and, failing such request, that the "B" sample shall be deemed to be waived. The athlete shall be advised at the same time that, if the "B" sample analysis is requested, all related laboratory costs shall be met by the athlete, unless the "B" sample fails to confirm the "A", in which case the costs shall be met by the organization responsible for initiating the test;
 - (e) the date upon which the "B" sample analysis, if requested by the athlete, has been fixed, such date normally to be no later than two weeks after the date of notification of the adverse

analytical finding to the athlete. If the laboratory concerned cannot subsequently accommodate the "B" sample analysis on the date fixed, the analysis shall take place at the earliest available date for the laboratory thereafter. No other reason shall be accepted for changing the date of the "B" sample analysis;

- (f) the right of the athlete and/or his representative to attend the "B" sample opening procedure and analysis, if such analysis is requested; and
 - (g) the athlete's right to request copies of the "A" and "B" sample laboratory documentation package which shall include the information required by the International Standard for Laboratories.
5. Following notification to an athlete under Rule 37.4(b), the IAAF Anti-Doping Administrator shall conduct any follow-up investigation that may be required. Upon the completion of such follow-up investigation, the IAAF Anti-Doping Administrator shall promptly notify the athlete of the results of the follow-up investigation and whether it is asserted that an Anti-Doping Rule violation has been committed. If this is the case, the athlete concerned shall then be afforded an opportunity, either directly or through his National Federation, within a time limit set by the IAAF Anti-Doping Administrator, to provide an explanation in response to the Anti-Doping Rule violation asserted.
 6. An athlete may accept an "A" sample analytical result by waiving his right to the "B" sample analysis. The IAAF may however request the analysis of a "B" sample at any time if it believes that such analysis will be relevant to consideration of the athlete's case.
 7. The athlete and/or his representative shall be allowed to be present at the "B" sample analysis and to attend throughout the analysis being carried out. A representative of the athlete's National Federation may also be present and attend throughout, as may a representative of the IAAF. An athlete shall remain provisionally suspended (see Rule 38.2) despite the fact that he has requested analysis of the "B" sample.
 8. Once the analysis of the "B" sample has been concluded, a full laboratory report shall be sent to the IAAF Anti-Doping Administrator together, in due course, with a copy of all relevant data required by the International Standard for Laboratories. A copy of this report and all relevant data shall be forwarded to the athlete if so requested.

9. On receipt of the "B" sample laboratory report, the IAAF Anti-Doping Administrator shall conduct any follow-up investigation that may be required by the Prohibited List. Upon completion of the follow-up investigation, the IAAF Anti-Doping Administrator shall promptly notify the athlete regarding the results of the follow-up investigation and whether or not the IAAF asserts, or continues to assert, that an Anti-Doping Rule has been violated.
10. Persons connected with doping control shall take all reasonable steps to maintain confidentiality in a case until the "B" sample analysis has been concluded (or until any follow-up investigation to the "B" sample analysis as may be required by the Prohibited List under Rule 37.9 has been concluded), or until the "B" sample analysis is waived by the athlete. The identity of athletes whose samples have resulted in an adverse analytical finding or who are alleged to have committed Anti-Doping Rule violations may be publicly disclosed in normal circumstances no earlier than the imposition of a provisional suspension in accordance with Rule 38.2 or Rule 38.3.
11. In the case of any Anti-Doping Rule violation where there is no adverse analytical finding, the IAAF Anti-Doping Administrator shall conduct any investigation based on the facts of the case that he deems to be necessary and, on completing such an investigation, shall promptly notify the athlete concerned whether it is asserted that an Anti-Doping Rule violation has been committed. If this is the case, the athlete shall be afforded an opportunity, either directly or through his National Federation, within a time limit set by the IAAF Anti-Doping Administrator, to provide an explanation in response to the Anti-Doping Rule violation asserted.
12. The results management process from a test conducted by the IOC or by any other international sports organisation body conducting testing at an International Competition over which the IAAF has no exclusive control (e.g. the Commonwealth Games or the Pan American Games) shall be managed, as far as determining an athlete's sanction beyond disqualification from the International Competition in question, by the IAAF in accordance with these Anti-Doping Rules.

RULE 38

Disciplinary Procedures

1. Where it is asserted that an Anti-Doping Rule violation has been committed under these Anti-Doping Rules, disciplinary

procedures shall take place in the following three stages:

- (a) provisional suspension;
- (b) hearing;
- (c) sanction or exoneration.

Provisional Suspension

2. If no explanation, or no adequate explanation, for the asserted Anti-Doping Rule violation is received from the athlete or his National Federation within the time limit set by the IAAF Anti-Doping Administrator in Rule 37.4(c) or 37.11, the athlete shall be suspended, suspension at this time being provisional pending resolution of the athlete's case by his National Federation. In the case of an International-Level athlete, the athlete shall be suspended by the IAAF Anti-Doping Administrator. In all other cases, the National Federation of the athlete shall impose the relevant suspension by written notification to the athlete. Alternatively, the athlete may accept a voluntary suspension provided that this is confirmed in writing to his National Federation.
3. In any case where the Member imposes a provisional suspension or an athlete accepts a voluntary suspension, the Member shall confirm this fact to the IAAF immediately and the athlete shall thereafter be subject to the disciplinary procedures set out below. A voluntary suspension shall be effective only from the date of receipt of the athlete's written confirmation of such by the IAAF. If, contrary to the above paragraph, the Member fails, in the opinion of the IAAF Anti-Doping Administrator, to impose a provisional suspension as required, the IAAF Anti-Doping Administrator shall himself impose such a provisional suspension. Once the provisional suspension is imposed by the IAAF Anti-Doping Administrator, it shall notify the suspension to the Member which must then commence the disciplinary procedures set out below.
4. A decision to impose a provisional suspension on an athlete shall not be subject to an appeal. An athlete who has been provisionally suspended, or who has accepted a voluntary suspension shall, however, be entitled to a full expedited hearing before his Member in accordance with Rule 38.7.

Hearing

5. Every athlete shall have the right to request a hearing before the relevant tribunal of his National Federation before any sanction is determined in accordance with these Anti-Doping Rules. When

an athlete has obtained affiliation status abroad under Rule 4.3, he shall have the right to request a hearing either before the relevant tribunal of his original National Federation or before the relevant tribunal of the Member whose affiliation has been obtained.

6. When an athlete is notified that his explanation has been rejected and that he is to be provisionally suspended in accordance with Rule 38.2, he shall also be told of his right to request a hearing. If the athlete fails to confirm in writing to his National Federation or other relevant body within 14 days of such notice that he wishes to have a hearing, he will be deemed to have waived his right to a hearing and to have accepted that he committed the Anti-Doping Rule violation in question. This fact shall be confirmed in writing to the IAAF by the Member within 5 working days.
7. If a hearing is requested by an athlete, it shall be convened without delay and the hearing held within two months of the date of notification of the athlete's request to the Member. Members shall keep the IAAF fully informed as to the status of all cases pending hearing and of all hearing dates as soon as they are fixed. The IAAF shall have the right to attend all hearings as an observer. However, the IAAF's attendance at a hearing, or any other involvement in a case, shall not affect its right to appeal the Member's decision to CAS pursuant to Rule 60.23.
8. The athlete's hearing shall take place before the relevant hearing body constituted or otherwise authorised by the Member. The relevant hearing body shall be fair and impartial and the conduct of the hearing shall respect the following principles: the right of the athlete to be present at the hearing and to present evidence, including the right to call and question witnesses, the right to be represented by legal counsel and an interpreter (at the athlete's expense) and a timely and reasoned decision in writing.
9. At the hearing of the athlete's case, the relevant tribunal shall consider first whether or not an Anti-Doping Rule violation has been committed. The Member or other prosecuting authority shall have the burden of proving the Anti-Doping Rule violation to the comfortable satisfaction of the tribunal (see Rule 33.2).
10. If the relevant tribunal of the Member considers that an Anti-Doping Rule violation has not been committed, this decision shall be notified to the IAAF Anti-Doping Administrator in writing within five working days of the decision being made (together with a copy of the written reasons for such decision). The case shall then be reviewed by the Doping Review Board which shall

decide whether or not it should be referred to arbitration before CAS pursuant to Rule 60.23. If the Doping Review Board does so decide, it may at the same time re-impose, where appropriate, the athlete's provisional suspension pending resolution of the appeal by CAS.

11. If the relevant tribunal of the Member considers that an Anti-Doping Rule violation has been committed, prior to the imposition of any period of ineligibility, the athlete shall have the opportunity to establish that there are exceptional circumstances in his case justifying a reduction of the sanction otherwise applicable under Rule 40.1.

Exceptional Circumstances

12. All decisions taken under these Anti-Doping Rules regarding exceptional circumstances must be harmonised so that the same legal conditions can be guaranteed for all athletes, regardless of their nationality, domicile, level or experience. Consequently, in considering the question of exceptional circumstances, the following principles shall be applied:
 - (a) it is each athlete's personal duty to ensure that no prohibited substance enters his body tissues or fluids. Athletes are warned that they shall be held responsible for any prohibited substance found to be present in their bodies (see Rule 32.2(a)(i)).
 - (b) exceptional circumstances will exist only in cases where the circumstances are truly exceptional and not in the vast majority of cases.
 - (c) taking into consideration the athlete's personal duty in Rule 38.12(i), the following will not be regarded as cases which are truly exceptional: an allegation that the prohibited substance or prohibited method was given to an athlete by another person without his knowledge, an allegation that the prohibited substance was taken by mistake, an allegation that the prohibited substance was due to the taking of contaminated food supplements or an allegation that medication was prescribed by athlete support personnel in ignorance of the fact that it contained a prohibited substance.
 - (d) exceptional circumstances may however exist where an athlete has provided substantial evidence or assistance to the IAAF, his National Federation or other relevant body which has resulted in the IAAF, his National Federation or other relevant body discovering or establishing an Anti-Doping

Rule violation by another person involving possession (under Rule 32.2(f)), trafficking (under Rule 32.2(g)) or administration to an athlete (under Rule 32.2(h)).

13. The determination of exceptional circumstances in cases involving International-Level athletes shall be made by the Doping Review Board (see Rule 38.17).
14. If an athlete seeks to establish that there are exceptional circumstances in his case, the relevant tribunal shall consider, based on the evidence presented, and with strict regard to the principles set out in Rule 38.12, whether, in its view, the circumstances in the athlete's case may be exceptional.
15. If, having examined the evidence presented, the relevant tribunal considers that there are no exceptional circumstances in the athlete's case, it shall impose the sanction prescribed in Rule 40.1. The Member shall notify the IAAF and the athlete in writing of the relevant tribunal's decision, within five working days of the decision being made.
16. If, having examined the evidence presented, the relevant tribunal considers that there are circumstances in the athlete's case which may be exceptional, if the case involves an International-Level athlete, it shall:
 - (a) refer the matter to the Doping Review Board (via the General Secretary), together with all material and/or evidence which, in its view, demonstrates the exceptional nature of the circumstances; and
 - (b) invite the athlete and/or his National Federation to support the referral of the relevant tribunal or to make independent submissions in support of such referral; and
 - (c) adjourn the hearing of the athlete's case pending the Doping Review Board's determination on exceptional circumstances.The athlete's provisional suspension shall remain in place pending the receipt of the Doping Review Board's determination on exceptional circumstances.
17. Upon receipt of a reference from the relevant tribunal, the Doping Review Board shall examine the question of exceptional circumstances only, on the basis of the written materials which have been submitted to it. The Doping Review Board shall have the power:
 - (a) to exchange views on the matter by e-mail, telephone, facsimile or in person;
 - (b) to call for further evidence or documents;
 - (c) to call for any further explanation from the athlete;

- (d) if necessary, to request the attendance of the athlete before it. Based on a review of the written materials submitted to it, including any further evidence or documents, or further explanation provided by the athlete, the Doping Review Board, having strict regard to the principles set out in Rule 38.12, shall make a determination on whether there are exceptional circumstances in the case and, if so, into which category they fall, i.e., whether the exceptional circumstances demonstrate no fault or no negligence on the athlete's part (see Rule 40.2) or no significant fault or no significant negligence on the athlete's part (see Rule 40.3) or substantial evidence or assistance by the athlete resulting in discovering or establishing an Anti-Doping Rule violation by another person (see Rule 40.4). This determination shall be conveyed to the Member in writing by the General Secretary.
18. If the Doping Review Board's determination is that there are no exceptional circumstances in the case, the determination shall be binding on the relevant tribunal, which shall impose the sanction prescribed in Rule 40.1. The Member shall notify the IAAF and the athlete in writing of the relevant tribunal's decision, which shall incorporate the Doping Review Board's determination, within 5 working days of the decision being made.
 19. If the Doping Review Board's determination is that there are exceptional circumstances in the case, the relevant tribunal shall decide the athlete's sanction in accordance with Rules 40.2, 40.3 or 40.4, consistent with the Doping Review Board's categorisation of the exceptional circumstances in Rule 38.17. The Member shall notify the IAAF and the athlete of the relevant tribunal's decision in writing, within five working days of the decision being made.
 20. The athlete shall have the right to seek a review of the Doping Review Board's determination on exceptional circumstances to CAS, either as part of an appeal against the decision of the Member in accordance with Rule 60.10(a) or pursuant to Rule 60.10(b). In all cases, the standard of review of the Doping Review Board's determination on the question of exceptional circumstances shall be as set out in Rule 60.27.
 21. In cases which do not involve International-Level athletes, the relevant tribunal shall consider, having strict regard to the principles set out in Rule 38.12, whether there are exceptional circumstances in the athlete's case and decide upon the athlete's sanction accordingly. The Member shall notify the IAAF and the

athlete of the relevant tribunal's decision in writing, within five working days of the decision being made. If the relevant tribunal concludes that there are exceptional circumstances in an athlete's case, it shall set out the full factual basis for such conclusion as part of its written decision.

RULE 39

Disqualification of Results

1. Where an Anti-Doping Rule violation occurs in connection with an in-competition test, the athlete shall be automatically disqualified from the event in question and from all subsequent events of the competition, with all resulting consequences for the athlete, including the forfeiture of all titles, awards, medals, points and prize and appearance money.
2. Where the athlete who commits an Anti-Doping Rule violation under Rule 39.1 is a member of a relay team, the relay team shall be automatically disqualified from the event in question, with all resulting consequences for the relay team, including the forfeiture of all titles, awards, medals, points and prize and appearance money. If the athlete who has committed an Anti-Doping Rule violation competes for a relay team in a subsequent event in the competition, the relay team shall be disqualified from the subsequent event, with all the same resulting consequences for the relay team, including the forfeiture of all titles, awards, medals, points and prize and appearance money.
3. Where the athlete who commits an Anti-Doping Rule violation under Rule 39.1 is a member of a team other than a relay team, in an event where a team ranking is based on the addition of individual results, the team shall not be automatically disqualified from the event in question but the result of the athlete committing the violation will be subtracted from the team result and replaced with the result of the next applicable team member. If by subtracting the athlete's result from the team's result, the number of athletes counting for the team is less than the required number, the team shall be eliminated from the ranking. This same principle shall apply to the calculation of a team result if the athlete who has committed an Anti-Doping Rule violation competes for a team in a subsequent event in the competition.
4. In addition to the above, where an athlete has been declared ineligible under Rule 40, all competitive results obtained from the date the positive sample was provided (whether in-competition or out-of-competition) or other Anti-Doping Rule violation occurred

through to the commencement of the period of provisional suspension or ineligibility shall, unless fairness requires otherwise, be annulled, with all resulting consequences for the athlete (and, where applicable, any team in which the athlete has competed), including the forfeiture of all titles, awards, medals, points and prize and appearance money.

5. Where an athlete commits an Anti-Doping Rule violation under Rule 32.2(b)(ii), all competitive results obtained subsequent to the admitted violation (both individual and, where applicable, as part of a team) shall be annulled, with all resulting consequences for the athlete (and, where applicable, the team in which the athlete competed), including the forfeiture of all titles, awards, medals, points and prize and appearance money and this from the date the athlete admitted the Anti-Doping Rule violation.

RULE 40

Sanctions against Individuals

1. If any person commits an Anti-Doping Rule violation under these Anti-Doping Rules, he shall be subject to the following sanctions:
 - (a) for a violation under Rules 32.2(a), (b) or (f) (prohibited substances and prohibited methods), except where the prohibited substance is a specified substance in a case under Rule 40.5, or Rule 32.2(i) (competing whilst suspended or ineligible):
 - (i) first violation: for a minimum period of two years' ineligibility.
 - (ii) second violation: ineligibility for life
 - (b) for a violation under Rule 32.2(c) (refusal or failure to submit to doping control) or Rule 32.2(e) (tampering with doping control):
 - (i) first violation: for a minimum period of two years' ineligibility.
 - (ii) second violation: ineligibility for life.
 - (c) for a violation under Rule 32.2(d) (three missed tests):
 - (i) first violation: for a period of one year's ineligibility.
 - (ii) second and subsequent violations: for a period of two years' ineligibility.
 - (d) for a violation under Rules 32.2(g) (trafficking) or (h) (administration of a prohibited substance or prohibited method):
 ineligibility for life.

In addition, violations under Rule 40.1(d) which also violate non-

sporting laws and regulations may be reported to the competent administrative, professional or judicial authorities.

Elimination, reduction or replacement of ineligibility period

2. If, in a case involving an Anti-Doping Rule violation under:
- (a) Rule 32.2(a) (presence of a prohibited substance); or
 - (b) Rule 32.2(b) (use of a prohibited substance or prohibited method);

the relevant tribunal of the Member decides (where applicable, having referred the matter to the Doping Review Board for its determination under Rule 38.16) that there are exceptional circumstances in the case such that the athlete or other person bears no fault or negligence for the violation, the otherwise applicable period of ineligibility under Rule 40.1(a) shall be eliminated. When a prohibited substance is detected in an athlete's sample in violation of Rule 32.2(a) (presence of a prohibited substance), the athlete must establish how the prohibited substance entered his system in order to have his period of ineligibility eliminated.

In the event that this Rule is applied and the period of ineligibility otherwise applicable under Rule 40.1(a) is eliminated, the Anti-Doping Rule violation shall not be considered a violation for the limited purpose of determining the period of ineligibility for multiple violations under Rules 40.1(a) to (c) and Rules 40.5 and 40.6 to 40.8.

3. If, in a case involving an Anti-Doping Rule violation under:
- (a) Rule 32.2(a) (presence of a prohibited substance);
 - (b) Rule 32.2(b) (use of a prohibited substance or prohibited method);
 - (c) Rule 32.2(c) (refusal or failure to submit to doping control);
 - (d) Rule 32.2(h) (administration of a prohibited substance or prohibited method); or
 - (e) Rule 32.2(i) (competing whilst suspended or ineligible)

the relevant tribunal of the Member decides (where applicable, having referred the matter to the Doping Review Board for its determination under Rule 38.16) that there are exceptional circumstances such that the athlete or other person bears no significant fault or no significant negligence for the violation, the period of ineligibility may be reduced but the reduced period may not be less than half the minimum period of ineligibility otherwise applicable. If the otherwise applicable period is a lifetime, the reduced period under this Rule may be no less than

eight years. When a prohibited substance is detected in an athlete's sample in violation of Rule 32.2(a) (presence of a prohibited substance), the athlete must establish how the prohibited substance entered his system in order to have his period of ineligibility reduced.

4. The relevant tribunal of the Member may also decide (where applicable, having referred the matter to the Doping Review Board for its determination under Rule 38.16) to reduce the period of ineligibility in an individual case on account of exceptional circumstances because the athlete or other person has provided substantial evidence or assistance to the IAAF, his National Federation or other relevant body which has resulted in the IAAF, National Federation or other relevant body discovering or establishing an Anti-Doping Rule violation by another person involving possession (under Rule 32.2(f)), trafficking (under Rule 32.2(g)) or administration to an athlete (under Rule 32.2(h)). The reduced period may not, however, be less than half the minimum period of ineligibility otherwise applicable. If the otherwise applicable period is a lifetime, the reduced period under this Rule may be no less than eight years.

Specified Substances

5. The Prohibited List may identify a limited number of specified substances which are particularly susceptible to unintentional Anti-Doping Rule violations because of their general availability in medicinal products or which are less likely to be successfully abused as doping agents. Where the athlete can establish that the use of such a specified substance was not intended to enhance performance, the period of ineligibility otherwise applicable in Rule 40.1(a) shall be replaced by:
 - (a) first violation:
 - (i) minimum: a public warning (and disqualification from the event and subsequent events in which he competed in the competition – see Rule 39) and no ineligibility from future competitions;
 - (ii) maximum: one year's ineligibility.
 - (b) second violation: for a period of two years' ineligibility.
 - (c) third violation: ineligibility for life.

Rules for multiple violations

6. For the purposes of imposing sanctions under Rules 40.1(a) to (c) and Rule 40.5, a second or further Anti-Doping Rule violation may only be considered if the IAAF, the Member or other

prosecuting authority can establish that the athlete or other person subject to these Anti-Doping Rules committed the second or further Anti-Doping Rule violation after he received notice, or after the Member made a reasonable attempt to give notice, of the first or previous violation. If the IAAF, Member or other prosecuting authority cannot establish this fact, the relevant Anti-Doping Rule violations shall be considered as a single violation and the sanction imposed shall be based on the violation that carries with it the more severe sanction.

7. Where, arising from the same test, an athlete is found to have committed an Anti-Doping Rule violation involving both a specified substance and another prohibited substance or prohibited method, the athlete shall be considered to have committed a single Anti-Doping Rule violation but the sanction imposed shall be based on the violation that carries with it the more severe sanction.
8. Where an athlete is found to have committed two separate Anti-Doping Rule violations (which have not arisen from the same test), one involving a specified substance governed by the sanctions in Rule 40.5 and the other involving a prohibited substance or prohibited method governed by the sanctions in Rule 40.1(a) or other violation governed by the sanctions in Rules 40.1(a) or (b), regardless of the order in which the two violations are committed, the period of ineligibility imposed for the second violation shall be a minimum of two years and a maximum of three years. An athlete found to have committed a third violation involving any combination of a violation for a specified substance under Rule 40.5 and any of the violations under Rules 40.1(a) to (c) shall receive a sanction of ineligibility for life.

Commencement of ineligibility period

9. In any case where a period of ineligibility is to be imposed under this Rule, the period of ineligibility shall start on the date of the hearing decision providing for ineligibility or, if the hearing is waived, on the date the ineligibility is accepted or otherwise imposed. When an athlete has served a period of provisional suspension prior to being declared ineligible (whether imposed or voluntarily accepted), such a period shall be credited against the total period of ineligibility to be served.

Status during ineligibility

10. No athlete, athlete support personnel or other person who has been declared ineligible may, during the period of ineligibility,

participate in any capacity in any competition or activity (other than in authorised anti-doping education or rehabilitation programmes) which are authorised or organised by the IAAF or any Member. In addition, for any Anti-Doping Rule violation not involving specified substances, some or all sports-related financial support or other sport-related benefits received by such person will be withheld by the IAAF and its Members.

|| ***No entitlement to payments or medals following ineligibility***

- || 11. Where an athlete has been declared ineligible, he shall not be entitled to any payment or medal to which he would have been entitled by virtue of his appearance and/or performance either at the competition at which the sample was provided or at any competition after the provision of the sample prior to him being provisionally suspended (or accepting a voluntary provisional suspension) pursuant to Rule 38.2. An athlete who has originally placed behind the ineligible athlete in a competition and who has been paid less prize money for his performance as a result of a payment made to the ineligible athlete shall not be entitled to any additional or "top-up" prize money unless and until all repayments of prize money by the ineligible athlete under Rule 40.12 have been duly received by the relevant person or entity.

|| ***Requirements for return to competition following ineligibility***

- || 12. In the event that the ineligible athlete, contrary to Rule 40.11, has received any payment or medal, he shall not be entitled to return to competition at the end of his period of ineligibility until such time as any and all payments have been repaid and any and all medals returned to the relevant person or entity.
- || 13. Where an International-Level athlete has been declared ineligible under Rule 40.1 for a period other than life, as a condition to regaining eligibility at the end of the specified period, he must, at any time during his period of ineligibility, make himself available for out-of-competition testing by the IAAF, his National Federation and any other organisation having competent testing authority under these Anti-Doping Rules, and he must provide whereabouts information to the IAAF for this purpose in accordance with Rule 35.16. Where an athlete has been rendered ineligible for one year or more, a minimum of three out-of-competition tests must be conducted, at the athlete's cost, with at least three months between each test. The IAAF shall be responsible for the conduct of the necessary tests, in accordance with the Rules and the Procedural Guidelines, but tests by any

competent testing body may be relied upon to satisfy this requirement, provided the samples collected have been analysed by a WADA-accredited laboratory. In addition, immediately prior to the end of the ineligibility period, an athlete must undergo testing for the full range of prohibited substances and methods. Where an athlete competing in Running Events, Race Walking events or Combined Events has been found guilty of an Anti-Doping Rule violation under the Rules, at least his last two reinstatement tests shall be analysed for rh-EPO and its related substances. The results of all such tests, together with copies of the relevant doping control forms, must be sent to the IAAF prior to the athlete returning to competition.

14. If the results of any testing carried out pursuant to Rule 40.12 should give rise to an adverse analytical finding or other Anti-Doping Rule violation under these Anti-Doping Rules, this will constitute a separate Anti-Doping Rule violation and the athlete will be subject to disciplinary proceedings and further sanction, as appropriate.
15. Once the period of an athlete's ineligibility has expired, provided that he has complied with Rules 40.11 and 40.12, he shall become automatically re-eligible and no application by the athlete or his National Federation to the IAAF shall be necessary.

RULE 41

Member Reporting Obligations

1. Every Member shall report to the IAAF promptly the names of athletes who have signed a written acknowledgement and agreement to these Anti-Doping Rules and the Procedural Guidelines in order to be eligible to compete in International Competitions (see Rule 30.5). A copy of the signed agreement shall in each case be forwarded by the Member to the IAAF Office.
2. Every Member shall report to the IAAF and WADA promptly any TUEs that are granted in accordance with Rule 34.5(b).
3. Every Member shall report to the IAAF promptly, and in all circumstances, within 14 days of notice to it, any adverse analytical finding obtained in the course of doping controls carried out by that Member or in that Member's Country or Territory, together with the name of the athlete concerned.
4. Every Member shall report, as part of its annual report to the IAAF to be submitted within the first three months of each year (see Article 4.9 of the Constitution), all doping controls

conducted by that Member or conducted in that Member's Country or Territory in the previous year (other than by the IAAF). This report shall be sorted by athlete, identifying when the athlete was tested, the entity conducting the test and whether the test was in or out-of-competition. The IAAF may choose periodically to publish such data as is received from its Members under this Rule.

5. The IAAF shall report to WADA every second year on the IAAF's compliance with the Code, including the compliance of its Members. The IAAF shall be required to explain any reasons for non-compliance.

RULE 42

Sanctions against Members

1. The Council shall have authority to take sanctions against any Member which is in breach of its obligations under these Anti-Doping Rules, in accordance with Article 14.7 of the Constitution.
2. The following examples will be considered to be a breach of a Member's obligations under these Anti-Doping Rules:
 - (a) a failure to guarantee an athlete's eligibility to compete in International Competitions by requiring the athlete sign a prior written acknowledgement and agreement to these Anti-Doping Rules and the Procedural Guidelines and forwarding a copy of the signed agreement to the IAAF Office (see Rule 30.5).
 - (b) a failure to hold a hearing for an athlete within two months of being requested to do so (see Rule 38.7);
 - (c) a failure to make diligent efforts to assist the IAAF in the collection of whereabouts information should the IAAF make such a request for assistance (see Rule 35.16);
 - (d) a failure to report to the IAAF and WADA the grant of any TUE under Rule 34.5(b) (see Rule 41.2);
 - (e) a failure to report to the IAAF an adverse analytical finding obtained in the course of a doping control carried out by that Member, or in that Member's Country or Territory, within 14 days of notice of such a finding to the Member, together with the name of the athlete concerned (see Rule 41.3);
 - (f) a failure to report to the IAAF as part of its annual report to be submitted within the first three months of the year, a list of all doping controls conducted by that Member or in that Member's Country or Territory in the previous year (see

Rule 41.4).

3. If a Member is deemed to be in breach of its obligations under these Anti-Doping Rules, the Council shall have authority to act in one or more of the following ways:
 - (a) to suspend the Member until the next meeting of the Congress or for any shorter period;
 - (b) to caution or censure the Member;
 - (c) to issue fines;
 - (d) to withhold grants or subsidies from the Member;
 - (e) to exclude the Member's athletes from any one or more International Competition;
 - (f) to remove or deny accreditation to the officers or other representatives of the Member; and
 - (g) to issue any other sanction as it may deem to be appropriate.
4. In any case where the Council has issued a sanction against a Member for a breach of its obligations under these Anti-Doping Rules, such a decision shall be reported to the next Congress.

RULE 43

Recognition

1. Where doping controls have been carried out by the IAAF, a Member or an Area Association in accordance with these Anti-Doping Rules and the Procedural Guidelines, every Member shall recognise the results of such doping controls. Furthermore, where decisions have been taken by the IAAF or a Member regarding a breach of these Anti-Doping Rules, every Member shall recognise such decisions and shall take all necessary action to render such decisions effective.
2. The Council may, on behalf of all Members, recognise the results of doping controls carried out by a sporting body other than the IAAF, whether national, regional, continental or international, or by a member of that sporting body, or by any government or governmental agency, under rules and procedures different from those of the IAAF, if it is satisfied the testing was properly carried out and the rules of the body conducting the testing afford sufficient protection to athletes.
3. The Council may delegate its responsibility for the recognition of the results of doping controls under Rule 43.2 to the Doping Review Board or to such other person or body as it may deem to be appropriate.
4. If the Council (or its appointee under Rule 43.3) decides that the

result of a doping control carried out by a sporting body other than the IAAF, or by a government or governmental agency, is to be recognised, then the athlete shall be deemed to have breached the relevant Rule and will be subject to the same disciplinary procedures and sanctions as for a corresponding violation of these Anti-Doping Rules. All Members shall take all necessary action to ensure that any decision regarding an Anti-Doping Rule violation in such a case is effective.

RULE 44

Statute of Limitations

No disciplinary action may be commenced under these Anti-Doping Rules against an athlete or any other person for a violation of an anti-doping rule contained in these Anti-Doping Rules unless such action is commenced within eight years of the date on which the Anti-Doping Rule violation occurred.

RULE 45

Interpretation

1. Anti-Doping Rules are, by their nature, competition rules governing the conditions under which the sport of Athletics is to be held. They are not intended to be subjected to or limited by the requirements and legal standards applicable to criminal proceedings or employment matters. The policies and standards set out in the Code as a basis for the fight against doping in sport, and as accepted by the IAAF in these Anti-Doping Rules, represent a broad consensus of those with an interest in fair sport and should be respected by all courts and adjudicating bodies.
2. The various headings and sub-headings used in these Anti-Doping Rules are for convenience only and shall not be deemed to be part of the substance of these Anti-Doping Rules or to affect in any way the language of the provisions to which they refer.
3. The Definitions in Chapter 3 shall be considered an integral part of these Anti-Doping Rules.

CHAPTER 4: DISPUTES

RULE 60
Disputes

General

1. Unless otherwise stated in a specific Rule or Regulation (for example, in relation to disputes arising on the field of competition), all disputes arising under these Rules shall be resolved in accordance with the provisions set out below.

Disputes involving athletes, athlete support personnel and other persons

2. Each Member shall incorporate a provision in its constitution that, unless otherwise stated in a specific Rule or Regulation, all disputes involving athletes, athlete support personnel or other persons under its jurisdiction, however arising, whether doping or non-doping related, shall be submitted to a hearing before the relevant hearing body constituted or otherwise authorised by the Member. Such a hearing shall respect the following principles: a timely hearing before a fair and impartial hearing body, the right of the individual to be informed of the charge against him, the right to present evidence, including the right to call and question witnesses, the right to be represented by legal counsel and an interpreter (at the individual's expense) and a timely and reasoned decision in writing. Where such disputes arise in a non-disciplinary context, the relevant hearing body shall be constituted as an arbitration panel.
3. In the event of a breach of the Anti-Doping Rule violations in Chapter 3, the Member shall apply the disciplinary procedures set out in Rule 38. The Member shall inform the IAAF in writing of the decision taken within 5 working days of the decision being made (and shall send the IAAF a copy of the written reasons for the decision in English or French).
4. In the event of an alleged breach of Rule 22 relating to Ineligibility for International and Domestic Competitions (other than in a case of breach of Rule 22.1(e)), the Member shall apply the disciplinary procedures set out below:
 - (a) The allegation shall be reduced to writing and forwarded to the Member to which the athlete, athlete support personnel

- or other person is affiliated, which shall proceed in a timely manner to hold an investigation into the facts of the case.
- (b) If, following such investigation, the Member believes that there is evidence to support the allegation of ineligibility, the Member shall immediately notify the athlete or other person concerned of the charge to be brought and of his right to a hearing before any decision on ineligibility is made. If the athlete or other person fails to confirm in writing to the Member or other relevant body within 14 days of such notice that he wishes to have a hearing, he will be deemed to have waived his right to a hearing and to have accepted that he committed a breach of the relevant provision of Rule 22.
 - (c) If the athlete or other person confirms that he wishes to have a hearing, all relevant evidence shall be given to the person whose eligibility is challenged and a hearing respecting the principles set out in Rule 60.2 shall be held within a period of no more than 2 months following notification of the charge in Rule 60.4(b). The Member shall inform the IAAF as soon as a hearing date is set and the IAAF shall have the right to attend the hearing as an observer. The IAAF's attendance at the hearing in such capacity, or any other involvement in the case, shall not affect its right to appeal the decision to CAS in accordance with Rule 60.24.
 - (d) If the relevant hearing body of the Member, after hearing the evidence, decides that the athlete or other person concerned is in breach of Rule 22, it shall declare the person ineligible from international and domestic competitions for a period set out in Guidelines produced by the Council (or the Member shall do so if the athlete or other person has waived his right to a hearing). In the absence of such Guidelines, the relevant hearing body shall determine the appropriate period of the person's ineligibility.
 - (e) The Member shall inform the IAAF in writing of the decision taken within 5 working days of the decision being made (and shall send the IAAF a copy of the written reasons for the decision).
5. Where a Member delegates the conduct of a hearing to any body, committee or tribunal (whether within or outside the Member), or where for any other reason, any national body, committee or tribunal outside of the Member is responsible for affording an athlete, athlete support personnel or other person his hearing under these Rules, the decision of that body, committee or

tribunal shall be deemed, for the purposes of Rule 60.10, to be the decision of the Member and the word "Member" in such Rule shall be so construed.

Disputes between a Member and the IAAF

6. Each Member shall incorporate a provision in its constitution that, unless otherwise stated in a specific Rule or Regulation, all disputes arising between a Member and the IAAF shall be referred to the Council. The Council shall determine a procedure for the adjudication of the dispute depending on the circumstances of the case in question.
7. In the event that the IAAF seeks to suspend a Member for a breach of the Rules, the Member must have been sent prior notice in writing of the grounds for the suspension and must have been given a reasonable opportunity to be heard on the matter in accordance with the procedures set out in Article 14.10 of the Constitution.

Disputes between Members

8. Each Member shall incorporate a provision in its constitution that all disputes with another Member shall be referred to the Council. The Council shall determine a procedure for the adjudication of the dispute depending on the circumstances of the case in question.

Appeals

9. All decisions subject to appeal under these Rules, whether doping or non-doping related, may be appealed to CAS in accordance with the provisions set out below. All such decisions shall remain in effect while under appeal, unless determined otherwise (see Rules 60.23 and 60.24).
10. The following are examples of decisions that may be subject to appeal under these Rules:
 - (a) Where a Member has taken a decision that an athlete, athlete support personnel or other person has committed an Anti-Doping Rule violation.
 - (b) Where an athlete accepts a Member's decision that he has committed an Anti-Doping Rule violation but seeks a review of the Doping Review Board's determination under Rule 38.18 that there are no exceptional circumstances in the case justifying a reduction of the period of ineligibility to be served.
 - (c) Where a Member has taken a decision that an athlete, athlete

support personnel or other person has not committed an Anti-Doping Rule violation.

- (d) Where testing has indicated the presence of a prohibited substance or the use of a prohibited method and, contrary to Rule 38.7, the Member has refused or failed to provide the athlete with a hearing within the relevant time period.
 - (e) Where the IAAF has taken a decision to deny an International-Level athlete a TUE under Rule 34.5(a).
 - (f) Where the IAAF has issued a sanction against a Member for a breach of the Rules.
 - (g) Where a Member has taken a decision that an athlete, athlete support personnel or other person has not committed a breach of Rule 22.
11. In cases involving International-Level athletes (or their athlete support personnel), or involving the sanction of a Member by the Council for a breach of the Rules, whether doping or non-doping related, the decision of the relevant body of the Member or the IAAF (as appropriate) may be appealed exclusively to CAS in accordance with the provisions set out in Rules 60.25 to 60.30.
12. In cases which do not involve International-Level athletes (or their athlete support personnel), whether doping or non-doping related, the decision of the relevant body of the Member may (unless Rule 60.17 applies) be appealed to a national review body in accordance with Rule 60.15. Each Member shall have in place an appeal procedure at national level that respects the following principles: a timely hearing before a fair, impartial and independent hearing body, the right to be represented by legal counsel and interpreter (at the appellant's expense) and a timely and reasoned decision in writing. The decision of the national review body may be appealed to CAS in accordance with Rule 60.16.

Parties entitled to appeal decisions

13. In any case involving International-Level athletes (or their athlete support personnel), the following parties shall have the right to appeal a decision to CAS:
- (a) the athlete or other person who is the subject of the decision being appealed;
 - (b) the other party to the case in which the decision was rendered;
 - (c) the IAAF;
 - (d) the IOC (where the decision may have an effect on eligibility

- in relation to the Olympic Games); and
- (e) WADA (in doping-related matters only).
14. In any case involving a decision by the Council to sanction a Member for a breach of the Rules, the Member affected shall have the sole right to appeal a decision to CAS.
15. In any case which does not involve International-Level athletes (or their athlete support personnel), the parties having the right to appeal a decision to the national level review body shall be:
- (a) the athlete or other person the subject of the decision being appealed;
 - (b) the other party to the case in which the decision was rendered;
 - (c) the Member.

|| The IAAF shall not have the right to appeal a decision to the national level review body of the Member but shall be entitled to attend any hearing before the national-level review body as an observer. The IAAF's attendance at a hearing in such capacity shall not affect its right to appeal the decision of the national level review body to CAS in accordance with Rule 60.16.

- || 16. In any case which does not involve International-level athletes (or their athlete support personnel), the following parties shall have the right to appeal the decision of the national level review body to CAS:
- (a) the IAAF; and
 - (b) WADA (in doping-related cases only).
- || 17. In any case which does not involve International-Level athletes (or their athlete support personnel), the IAAF and WADA (in doping-related cases only) shall have the right to appeal a decision of the relevant body of the Member direct to CAS in accordance with the provisions of Rule 60 in any of the following circumstances:
- (a) the Member does not have an appeal procedure in place at the national level;
 - (b) there is no appeal made to the national review body of the Member by any of the parties in Rule 60.15;
 - (c) the Member's rules so provide.

Respondents to the CAS Appeal

18. Unless otherwise stated below, as a general rule, the respondent to a CAS appeal under these Rules shall be the party which has taken the decision which is the subject of the appeal.
19. In all references to CAS under Rules 60.10(a), (d) or (g), the

relevant Member shall be respondent. If however, in an appeal under Rule 60.10(a), the appellant seeks a review of a determination made by the Doping Review Board on exceptional circumstances under Rule 38.17, the respondents to the appeal shall be the relevant Member and the IAAF and they shall jointly appoint an arbitrator. If there is any disagreement as to who the appointed arbitrator should be, the IAAF's choice of arbitrator shall prevail.

20. In all references to CAS under Rules 60.10(b), (e) or (f), the respondent shall be the IAAF.
21. In all references to CAS under Rule 60.10(c), the respondents shall be the relevant Member and the athlete.
22. In any case where the IAAF or the relevant Member is not a party to the appeal before CAS, it may nevertheless choose to participate at the CAS hearing if it considers it appropriate to do so.

IAAF appeal of decisions to CAS

23. The decision by the IAAF as to whether a doping-related case should be appealed to CAS shall be taken by the Doping Review Board. The Doping Review Board shall, where applicable, determine at the same time whether the athlete concerned shall be re-suspended pending the CAS decision.
24. The decision by the IAAF as to whether a non-doping-related case should be appealed to CAS shall be taken by the Council. The Council shall, where applicable, determine at the same time whether the athlete concerned shall be suspended pending the CAS decision.

The CAS Appeal

25. Unless the Council determines otherwise, the appellant shall have 30 days from the date of communication of the written reasons of the decision to be appealed (in English or French where the IAAF is the prospective appellant) in which to file his statement of appeal with CAS. Within 15 days of the deadline for filing the statement of appeal, the appellant shall file his appeal brief with CAS and, within thirty days of receipt of the appeal brief, the respondent shall file his answer with CAS.
26. All appeals before CAS (save as set out in Rule 60.27) shall take the form of a re-hearing de novo of the issues raised by the case and the CAS Panel shall be able to substitute its decision for the decision of the relevant tribunal of the Member or the IAAF where it considers the decision of the relevant tribunal of the

- Member or the IAAF to be erroneous or procedurally unsound.
27. Where the appeal to CAS in a doping-related case is made pursuant to Rule 60.10(b), or is pursuant to Rule 60.10(a) and the athlete seeks as part of the appeal a review of the Doping Review Board's determination on exceptional circumstances, the hearing before CAS on the question of exceptional circumstances shall be limited to a review of the materials before the Doping Review Board and to its determination. The CAS Panel will only interfere with the determination of the Doping Review Board if it is satisfied:
 - (a) that no factual basis existed for the Doping Review Board's determination; or
 - (b) the determination reached was significantly inconsistent with the previous body of cases considered by the Doping Review Board, which inconsistency cannot be justified by the facts of the case; or
 - (c) that the determination reached by the Doping Review Board was a determination that no reasonable review body could reach.
 28. In all CAS appeals involving the IAAF, CAS and the CAS Panel shall be bound by the IAAF Constitution, Rules and Regulations (including the Procedural Guidelines). In the case of any conflict between the CAS rules currently in force and the IAAF Constitution, Rules and Regulations, the IAAF Constitution, Rules and Regulations shall take precedence.
 29. In all CAS appeals involving the IAAF, the governing law shall be Monegasque law and the arbitrations shall be conducted in English, unless the parties agree otherwise.
 30. The CAS Panel may in appropriate cases award a party its costs, or a contribution to its costs, incurred in the CAS appeal.
 31. The decision of CAS shall be final and binding on all parties, and on all Members, and no right of appeal will lie from the CAS decision. The CAS decision shall have immediate effect and all Members shall take all necessary action to ensure that it is effective. The fact of the referral to CAS and the CAS decision shall be set out in the next notice to be sent by the General Secretary to all Members.

CHAPTER 5: TECHNICAL RULES

RULE 100

General

All International Competitions, as defined in Rule 1.1, shall be held under the Rules of the IAAF and this shall be stated in all announcements, advertisements, programmes and printed material.

Note: It is recommended that Members adopt the Rules of the IAAF for the conduct of their own athletics competitions.

SECTION I - OFFICIALS

RULE 110

International Officials

At competitions organised under Rules 1.1(a), (b), (c) and (f), the following officials should be appointed internationally:

- (a) Organisational Delegate(s)
- (b) Technical Delegate(s)
- (c) Medical Delegate
- (d) Doping Control Delegate
- (e) International Technical Officials / International Cross Country, Road Running and Mountain Running Officials / Area Technical Officials
- (f) International Race Walking Judges/Area Race Walking Judges
- (g) International Road Course Measurer
- (h) International Starter(s)
- (i) International Photo Finish Judge
- (j) Jury of Appeal

The number of officials appointed in each category shall be indicated in the current IAAF (or Area Association) Technical Regulations.

At competitions organised under Rule 1.1(a):

The selection of persons under (a), (b), (c), (d), and (j) is made by the IAAF Council.

The selection of persons under (e) is made by the Council from

members of the IAAF Panels of International Technical Officials or the International Cross Country, Road Running and Mountain Running Officials respectively. The selection of persons under (f) is made by the IAAF Council from members of the IAAF Panel of International Race Walking Judges.

The selection of the person under (g) is made by the Technical Delegates from members of the IAAF/AIMS Panel of International Road Course Measurers. The selection of persons under (h) is made by the Technical Delegates from members of the IAAF Panel of International Starters. The selection of the person under (i) is made by the Technical Delegates from members of the IAAF Panel of International Photo Finish Judges.

The IAAF Council shall approve criteria of selection, qualification and duties of the above-mentioned officials. IAAF Members may suggest suitably qualified persons for selection.

At competitions organised under Rules 1.1(c) and (f) these persons will be selected by the relevant Area Associations. In the case of the Area Technical Officials and Area Race Walking Judges, the selection is made by the relevant Area Association from their own list of Area Technical Officials and Area Race Walking Judges.

For competitions organised under Rules 1.1(a), and (e)(i), IAAF may appoint an Advertising Commissioner. For competitions under Rules 1.1(c), (f) and (j), any such appointments will be made by the relevant Area Association, for competitions under Rule 1.1(b) by the relevant body, and for competition under Rules 1.1(d), (h) and (i), by the relevant IAAF Member.

Note: The International Officials should wear distinctive attire or insignia.

The travelling expenses of each individual appointed by the IAAF or an Area Association under this Rule or under Rule 3.2 shall be paid to the individual by the organisers of the competition not later than fourteen days prior to his departure to the venue. In cases involving flights over 1500 miles, business class return air travel shall be provided. Accommodation expenses shall also be paid by the organisers not later than the final day of the Championships or athletics section of the Games or on the day of the Meeting itself if the competition is a one-day meeting.

RULE 111

Organisational Delegates

The Organisational Delegates shall maintain close liaison with the Organising Committee at all times and report regularly to the IAAF

Council, and they shall deal as necessary with matters concerning the duties and financial responsibilities of the Organising Member and the Organising Committee. They shall cooperate with the Technical Delegate(s).

RULE 112
Technical Delegates

The Technical Delegates, in conjunction with the Organising Committee, which shall afford them all necessary help, are responsible for ensuring that all technical arrangements are in complete conformity with IAAF Technical Rules and the IAAF Track and Field Facilities Manual.

The Technical Delegates shall submit to the appropriate body proposals for the timetable of events, the entry standards, and implements to be used and shall determine the qualifying standards for the field events, and the basis on which heats and qualifying rounds shall be arranged for track events.

They shall ensure that the Technical Regulations are issued to all competing Members in good time before the competition.

The Technical Delegates are responsible for all other technical preparations necessary for the holding of the athletics events.

They shall control the entries and have the right to reject them for technical reasons or in accordance with the Rule 146.1. (Rejection for reasons other than technical must result from a ruling of the IAAF or appropriate Area Council.)

They shall arrange heats and qualifying rounds and the groups for the Combined Events competitions.

The Technical Delegates shall submit written reports as appropriate on the preparations for the competition.

They shall cooperate with the Organisational Delegate(s).

In competition under Rules 1.1(a), (b), (c) and (f), the Technical Delegates shall chair the Technical Meeting and shall brief the Technical Officials.

RULE 113
Medical Delegate

The Medical Delegate shall have ultimate authority on all medical matters. He shall ensure that adequate facilities for medical examination, treatment and emergency care will be available at the site of the competition and that medical attention can be provided where athletes are accommodated. The Medical Delegate shall also

have the authority to arrange for the determination of the gender of an athlete should he judge that to be desirable.

RULE 114

Doping Control Delegate

The Doping Control Delegate shall liaise with the Organising Committee to ensure that suitable facilities are provided for the conduct of doping control. He shall be responsible for all matters relating to doping control.

RULE 115

International Technical Officials (ITOs) and International Cross Country, Road Running and Mountain Running Officials (ICROs)

1. Where ITOs are appointed, the Technical Delegates shall appoint the Chief ITO among the appointed ITOs, if one was not appointed previously. Whenever possible, the Chief ITO shall assign at least one ITO for every event on the programme. The ITO shall provide all necessary support to the Referee of the event.

The ITOs must be present at all times when an event to which they have been assigned is in progress. They should ensure that the conduct of the competition is in full conformity with IAAF Technical Rules, Technical Regulations and relevant decisions made by the Technical Delegates.

If a problem arises or if they observe any matter which, in their opinion requires comment, they should, in the first instance, bring it to the attention of the Referee of the event and if necessary, offer advice as to what should be done. If the advice is not accepted and if there is a clear infringement of the IAAF Technical Rules, Technical Regulations or decisions made by the Technical Delegates, the ITO shall decide. If the matter is still not resolved it shall be referred to the IAAF Technical Delegate(s).

At the conclusion of field events they shall also sign the result cards.

Note (i): In competitions organised under Rules 1.1(c) and (f), the above shall also apply to the appointed Area Technical Officials.

Note (ii): In the absence of the Referee, the ITO shall work with the relevant Chief Judge.

2. In Cross Country, Road Running and Mountain Running competitions the appointed ICROs shall provide all necessary support to the competition organisers. They must be present at all times when an event to which they have been assigned is in progress. They should ensure that the conduct of the competition is in full conformity with IAAF Technical Rules, Technical Regulations and relevant decisions made by the Technical Delegates.

RULE 116

International Race Walking Judges

A Panel of International Race Walking Judges shall be established by the IAAF Race Walking Committee using criteria approved by the IAAF Council.

Race Walking Judges appointed for all Rule 1.1(a) International Competitions must be members of the Panel of International Race Walking Judges.

Note: Race Walking Judges appointed for Competitions under Rule 1.1(b), (c), (e)(ii), (f), (g) and (j) shall be members either of the Panel of International Race Walking Judges or one of the Panels of Area Race Walking Judges.

RULE 117

International Road Course Measurer

At competitions organised under Rule 1.1, an International Road Course Measurer shall be appointed to verify the courses where road events are held entirely or partially outside the stadium.

The appointed course measurer shall be member of the IAAF/AIMS Panel of International Road Course Measurers (Grade "A" or "B").

The course should be measured in good time before the competition.

The measurer will check and certify the course if he finds it conforms to the Rules for Road Races (See Rule 240.3 and respective Notes).

He shall cooperate with the Organising Committee in the course arrangements and witness the conduct of the race to ensure that the course run by athletes follows the same course that was measured and approved. He shall furnish an appropriate certificate to the Technical Delegate(s).

RULE 118

International Starter and International Photo Finish Judge

At all competitions under Rules 1.1(a), (b), (c) and (f) held in the stadium, an International Starter and an International Photo Finish Judge shall be appointed respectively by IAAF or the relevant Area Association. The International Starter shall start the races (and undertake any other duties) assigned to him by the Technical Delegate(s). The International Photo Finish Judge shall supervise all Photo Finish functions.

RULE 119

Jury of Appeal

At all competitions organised under Rules 1.1(a), (b), (c) and (f) a Jury of Appeal, which should normally consist of three, five or seven persons shall be appointed. One of its members shall be the Chairman and another the Secretary. If and when considered as appropriate, the Secretary may be a person not included in the Jury.

Furthermore, a Jury should likewise be appointed at other competitions where the organisers deem it desirable or necessary in the interest of the proper conduct of the competitions.

The primary functions of the Jury shall be to deal with all appeals under Rule 146, and with any matters arising during the course of the competition which are referred to it for decision. The Jury may reconsider a decision if new conclusive evidence is presented, provided the new decision is still applicable.

Decisions involving points which are not covered by the Rules, shall be reported subsequently by the Chairman of the Jury to the General Secretary of the IAAF.

RULE 120

Officials of the Competition

The Organising Committee of a competition shall appoint all officials, subject to the Rules of the Member in whose country the competition is held and, in the case of competitions under Rules 1.1(a), (b), (c) and (f), subject to the Rules and procedures of the appropriate international organisation.

The following list comprises the officials considered necessary for major International Competitions. The Organising Committee may, however, vary this according to local circumstances.

MANAGEMENT OFFICIALS

- One Competition Director
- One Meeting Manager
- One Technical Manager
- One Event Presentation Manager

COMPETITION OFFICIALS

- One Referee for the Call Room
- One (or more) Referee for Track Events
- One (or more) Referee for Field Events
- One (or more) Referee for Combined Events
- One (or more) Referee for events outside the Stadium
- One Chief Judge and an adequate number of Judges for Track Events
- One Chief Judge and an adequate number of Judges for each Field Event
- One Chief Judge and five Judges for each Track Race Walking Event
- One Chief Judge and eight Judges for each Road Race Walking Event
- Other Race Walking Competition officials, as necessary, including Recorders, Posting Board operators, etc.
- One Chief Umpire and an adequate number of Umpires
- One Chief Timekeeper and an adequate number of Timekeepers
- One Start Coordinator and an adequate number of Starters and Recalls
- One (or more) Starter's Assistant
- One Chief and an adequate number of Lap Scorers
- One Competition Secretary and an adequate number of assistants
- One Chief and an adequate number of Marshals
- One (or more) Wind Gauge Operator
- One Chief Photo Finish Judge and an adequate number of Assistant Photo Finish Judges
- One (or more) Measurement Judge (Electronics)
- One Chief and an adequate number of Call Room Judges

ADDITIONAL OFFICIALS

- One (or more) Announcer
- One (or more) Statistician
- One Advertising Commissioner
- One Official Surveyor
- One (or more) Doctor
- Stewards for Athletes, Officials and Press

Referees and Chief Judges should wear a distinctive attire or insignia. If deemed necessary, assistants may be appointed. Care should however be taken to keep the arena as free from officials as possible. Where women's events are held, a woman doctor shall be appointed when possible.

RULE 121

Competition Director

The Competition Director shall plan the technical organisation of a competition in cooperation with the Technical Delegate(s), where applicable, ensure that this plan is accomplished and resolve any technical problems together with the Technical Delegate(s).

He shall direct the interaction between the participants in the competition and, through the communication system, shall be in contact with all the officials.

RULE 122

Meeting Manager

The Meeting Manager shall be responsible for the correct conduct of the Competition. He shall check that all officials have reported for duty, appoint substitutes when necessary and have authority to remove from duty any official who is not abiding by the Rules. In cooperation with the appointed Marshal, he shall arrange that only authorised persons are allowed in the centre of the arena.

Note: For competitions of longer than four hours or over more than one day, it is recommended that the Meeting Manager has an adequate number of Assistant Meeting Managers.

RULE 123

Technical Manager

The Technical Manager shall be responsible for ensuring that the track, runways, circles, arcs, sectors, landing areas for field events and all equipment and implements are in accordance with IAAF Rules.

RULE 124

Event Presentation Manager

The Event Presentation Manager shall plan, in conjunction with the Competition Director, the event presentation arrangements for a competition, in cooperation with the Organisational and Technical

Delegate(s), as and where applicable. He shall ensure that the plan is accomplished, resolving any relevant problems together with the Competition Director and the relevant Delegate(s). He shall also direct the interaction between the members of the event presentation team, using the communication system to be in contact with each of them.

RULE 125

Referees

1. A separate Referee shall be appointed for the Call Room, for Track Events, for Field Events, for Combined Events and for Running and Race Walking Events outside the stadium.
The Referees for track events and for events outside the stadium shall have no jurisdiction over matters within the responsibilities of the Chief Judge of Race Walking events.
2. Referees shall ensure that the Rules (and applicable Technical Regulations) are observed and shall decide upon any matters which arise during the competition (including in the Call Room) and for which provision has not been made in these Rules (or any applicable Technical Regulations).
In case of a disciplinary case, the Call Room Referee has authority starting from the first Call Room up to the competition site.
The respective Referees for Track Events and for events outside the stadium shall have jurisdiction to decide placings in a race only when the Judges of the disputed place(s) are unable to arrive at a decision.
The relevant Track Referee has the power to decide on any facts related to the starts if he does not agree with the decisions made by the start team except in the cases when it regards a false start detected by an IAAF approved false start control apparatus, unless for any reason the Referee determines that the information provided by the apparatus is obviously inaccurate.
A Track Referee appointed to oversee the starts is designated the Start Referee.
The Referee shall not act as a Judge or Umpire.
3. The appropriate Referee shall check all final results, shall deal with any disputed points and, where there is no Measurement Judge (electronics), shall supervise the measurements of Record performances. At the conclusion of each event, the result card shall be completed immediately, signed by the appropriate Referee and handed to the Competition Secretary.

4. The appropriate Referee shall rule on any protest or objection regarding the conduct of the competition, including any matter arising in the Call Room.
5. He shall have authority to warn or exclude from competition, any athlete guilty of acting in an unsporting or improper manner. Warnings may be indicated to the athlete by showing a yellow card, exclusion by showing a red card. Warnings and exclusions shall be entered on the result card.
6. If, in the opinion of the appropriate Referee, circumstances arise at any competition such that justice demands that any event or any part of an event should be contested again, he shall have authority to declare the event void and it shall be held again, either on the same day or on some future occasion, as he shall decide.
7. The Combined Events Referee shall have jurisdiction over the conduct of the Combined Events competition. He shall also have jurisdiction over the conduct of the respective individual events within the Combined Events competition.

RULE 126

Judges

General

1. The Chief Judge for track events and the Chief Judge for each field event shall co-ordinate the work of the judges in their respective events. When the relevant body has not already allocated the duties of the Judges, they shall allocate the duties.

Track Events and Road Events

2. The Judges, who must all operate from the same side of the track or course, shall decide the order in which the athletes have finished and, in any case where they cannot arrive at a decision, shall refer the matter to the Referee, who shall decide.

Note: The Judges should be placed at least 5m from, and in line with, the finish and should be provided with an elevated platform.

Field Events

3. The Judges shall judge and record each trial and measure each valid trial of athletes in all field events. In the high jump and pole vault, precise measurements should be made when the bar is raised, particularly if Records are being attempted. At least two Judges should keep a record of all trials, checking their recordings at the end of each round.

The appropriate Judge shall indicate the validity or non-validity

of a trial by raising a white or red flag, as appropriate.

RULE 127

Umpires (Running and Race Walking Events)

1. Umpires are assistants to the Referee, without authority to make final decisions.
2. The Umpires shall be placed by the Referee in such a position that they may observe the competition closely and, in the case of a failure or violation of the Rules (other than Rule 230.1) by an athlete or other person, make an immediate written report of the incident to the Referee.
3. Any such breach of the Rules should be communicated to the relevant Referee by the raising of a yellow flag or any other reliable means approved by the Technical Delegate(s).
4. A sufficient number of Umpires shall also be appointed to supervise the take-over zones in relay races.

Note: When an Umpire observes that an athlete has run in a different lane from his own, or that a relay take-over has taken place outside the take-over zone, he should immediately mark on the track with suitable material the place where the infringement took place.

RULE 128

Timekeepers and Photo Finish Judges

1. In the case of hand timing, a sufficient number of timekeepers for the number of athletes entered shall be appointed. One of them shall be designated the Chief Timekeeper. He shall allocate duties to the Timekeepers. These Timekeepers shall act as back-up Timekeepers when Fully Automatic Photo Finish System is in use.
2. Timekeepers shall act in accordance with Rule 165.
3. When Fully Automatic Photo Finish System is used, a Chief Photo Finish Judge and at least two Assistant Photo Finish Judges shall be appointed.

RULE 129

Start Coordinator, Starter and Recalls

1. The Start Coordinator shall:
 - (a) Allocate the duties of the start team judges. In the case of competitions under 1.1(a) and Area Championships and Games, the determination of which events will be assigned

to the International Starters will be the responsibility of the Technical Delegates.

- (b) Supervise the duties to be fulfilled by each member of the team.
 - (c) Inform the Starter, after receiving the relevant order from the Competition Director, that everything is in order to initiate the start procedure (e.g. that the Timekeepers, the Judges and, when applicable, the Chief Photo Finish Judge and the Wind Gauge Operator are ready).
 - (d) Act as an interlocutor between the technical staff of the timing equipment company and the Judges.
 - (e) Keep all papers produced during the start procedure including all documents showing the reaction times and/or false start waveform images if available.
 - (f) Ensure that what is ruled under Rule 130.5 is fulfilled.
2. The Starter shall have entire control of the athletes on their marks. When a false start control apparatus is used, the Starter and/or an assigned Recaller shall wear headphones in order to hear clearly any acoustic signal emitted in the case of a false start (see Rule 161.2).
 3. The Starter shall position himself so that he has full visual control over all athletes during the start procedure.
It is recommended, especially for staggered starts, that loudspeakers in the individual lanes be used for relaying the commands to the athletes.
Note: The Starter shall place himself so that the whole field of athletes falls into a narrow visual angle. For races using crouch starts it is necessary that he is so placed that he can ascertain that all athletes are currently steady in their set positions before the gun is fired or approved starting apparatus is activated. Where loudspeakers are not used in races with a staggered start, the Starter shall so place himself that the distance between him and each of the athletes is approximately the same. Where, however, the Starter cannot place himself in such a position, the gun or approved starting apparatus shall be placed there and discharged by electric contact.
 4. One or more Recallers shall be provided to assist the Starter.
Note: For events of 200m, 400m, 400m Hurdles, 4x100m, 4x200m, 4x400m Relays, there shall be at least two Recallers.
 5. Each Recaller shall place himself so that he can see each athlete assigned to him.
 6. The warning and disqualification under Rule 162.7 and 162.8

may be made only by the Starter.

7. The Start Coordinator shall assign a specific task and position to each Recaller, who is obliged to recall the race if any infringement of the Rules is observed. After a recalled or aborted start the Recaller shall report his observations to the Starter who decides whether and to whom a warning shall be issued. (See also Rules 161.2 and 162.8.)
8. To assist in races using crouch starts, an IAAF approved false start control apparatus as described in Rule 161.2 should be used.

RULE 130

Starter's Assistants

1. The Starter's Assistants shall check that the athletes are competing in the correct heat or race and that their number bibs are worn correctly.
2. They must place each athlete in his correct lane or station, assembling the athletes approximately 3m behind the start line (in the case of races started in echelon, similarly behind each start line). When this has been completed, they shall signal to the Starter that all is ready. When a new start is ordered, the Starter's Assistants shall assemble the athletes again.
3. The Starter's Assistants shall be responsible for the readiness of batons for the first athletes in a relay race.
4. When the Starter has ordered the athletes to their marks, the Starter's Assistants must ensure that Rule 162.4 is observed.
5. In case of a first false start, the athlete(s) responsible for the false start shall be warned with a yellow card placed on the respective lane marker(s). At the same time, all the other athletes taking part in the race shall be warned with a yellow card raised in front of them by one or several starter's assistants in order to notify them that anyone committing further false starts will be disqualified. This last mentioned basic system (to raise a card in front of the athlete(s) responsible for the false start) will also be followed in case lane markers are not being used.
In case of further false starts, the athlete(s) responsible for the false start shall be disqualified and a red card shall be placed on the respective lane marker(s), or raised in front of the respective athlete(s).
In Combined Events, the athlete(s) responsible for a false start shall be warned with a yellow card placed on the respective lane marker(s) or raised in front of the respective athlete(s). Any athlete who is responsible for two false starts shall be disqualified

and a red card shall be placed on the respective lane marker or raised in front of the respective athlete.

RULE 131

Lap Scorers

1. Lap Scorers shall keep a record of the laps completed by all athletes in races longer than 1500m. For races of 5000m and longer, and for Race Walking events, a number of Lap Scorers under the direction of the Referee shall be appointed and provided with lap scoring cards on which they shall record the times over each lap (as given to them by an official Timekeeper) of the athletes for whom they are responsible. When such a system is used, no Lap Scorer should record more than four athletes (six for Race Walking events). Instead of manual lapscore, a computerised system, which may involve a transponder carried or worn by each athlete, may be used.
2. One Lap Scorer shall be responsible for maintaining, at the finish line, a display of the laps remaining. The display shall be changed each lap when the leader enters the straight that ends at the finish line. In addition, manual indication shall be given, when appropriate, to athletes who have been, or are about to be, lapped. The final lap shall be signalled to each athlete, usually by ringing a bell.

RULE 132

Competition Secretary

The Competition Secretary shall collect the full results of each event, details of which shall be provided by the Referee, the Chief Timekeeper or Chief Photo Finish Judge and the Wind-Gauge Operator. He shall immediately relay these details to the Announcer, record the results and convey the result card to the Competition Director.

Where a computerised results system is used the computer recorder at each field event site shall ensure that the full results of each event are entered into the computer system. The track results shall be input under the direction of the Chief Photo Finish Judge. The Announcer and the Competition Director shall have access to the results via a computer.

RULE 133

Marshal

The Marshal shall have control of the arena and shall not allow any

persons other than the officials and athletes assembled to compete or other authorised persons with valid accreditation to enter and remain therein.

RULE 134

Announcer

The Announcer shall inform the public of the names and numbers of the athletes taking part in each event, and all relevant information such as the composition of the heats, lanes or stations drawn, and intermediate times. The result (placings, times, heights, distances and points) of each event should be announced at the earliest possible moment after receipt of the information.

At competitions held under Rule 1.1(a), the English and French language Announcers shall be appointed by the IAAF. In conjunction with the Event Presentation Manager and under the general direction of the Organisational and/or the Technical Delegates, these appointees shall be responsible for all matters of announcing protocol.

RULE 135

Official Surveyor

The Official Surveyor shall check the accuracy of the markings and installations and shall furnish appropriate certificates to the Technical Manager before the competition.

He shall be given full access to stadium plans and drawings and the latest measurement report for the purpose of this verification.

RULE 136

Wind Gauge Operator

The Wind Gauge Operator shall ensure that the gauge is placed in accordance with Rule 163.9 (Track Events) and 184.5 (Field Events). He shall ascertain the velocity of the wind in the running direction in appropriate events and shall then record and sign the results obtained and communicate them to the Competition Secretary.

RULE 137

Measurement Judge (Electronics)

A Measurement Judge shall be appointed when Electronic Distance Measurement is to be used.

Before the start of the competition, he will meet the technical staff involved and familiarise himself with the equipment.

Before each event he will supervise the positioning of the measuring instruments, taking account of the technical requirements given by the technical staff.

To ensure that the equipment is operating correctly, he shall, before and after the event, supervise a set of measurements in conjunction with the Judges and Referee to confirm agreement with results achieved using a calibrated certified steel tape.

During the competition he shall remain in overall charge of the operation. He will report to the Field Events Referee to certify that the equipment is accurate.

RULE 138
Call Room Judges

The Call Room Chief Judge shall supervise the transit between the warm-up area and the competition area to ensure that the athletes, after being checked in the Call Room, be present and ready at the competition site for the scheduled start of their event.

The Call Room Judges shall ensure that athletes are wearing the national or club uniform clothing officially approved by their National Governing Body, that the number bibs are worn correctly and correspond with start lists, that shoes, number and dimension of spikes, advertising on clothing and athletes' bags comply with IAAF Rules and Regulations and that unauthorised material is not taken into the arena.

The judges shall refer any unresolved issues or matters arising to the Call Room Referee.

RULE 139
Advertising Commissioner

The Advertising Commissioner (when appointed) will supervise and apply the current IAAF Advertising Rules and Regulations and shall determine any unresolved advertising issues or matters arising in the Call Room in conjunction with the Call Room Referee.

SECTION II - GENERAL COMPETITION RULES**RULE 140****The Athletics Facility**

Any firm, uniform surface, which conforms to the specifications in the IAAF Track and Field Facilities Manual, may be used for athletics. Track and Field competitions under Rule 1.1(a) may be held only on synthetic surfaced facilities conforming to the IAAF Performance Specifications for Synthetic Surfaces and which hold a current valid IAAF Class 1 Athletics Facility Certificate.

It is recommended that, when such facilities are available, competitions under Rules 1.1(b) to (j) should also be held on these facilities.

In any case, a Class 2 Athletics Facility Certificate attesting to the dimensional accuracy of the Track and the Field Events facilities in the format required under the IAAF Certification System shall be required for all facilities intended for use for competitions under Rule 1.1(b) to (j).

Note (i): The IAAF Track and Field Facilities Manual available from the IAAF Office, contains more detailed and defined specifications for the planning and construction of track and field facilities including further diagrams for track measurement and marking.

Note (ii): Standard forms of Facility Certification Application and Facility Measurement Report are available from the IAAF Office, or may be downloaded from the IAAF website.

Note (iii): This Rule does not apply to Road Race Walking, Road Running or Cross-Country courses. (See Rules 230.10, 240.2, 240.3 250.3, 250.4 and 250.5)

RULE 141**Age Groups**

The following definitions apply to the age groups recognised by IAAF:

Youth Boys and Girls: Any athlete of 16 or 17 years on 31st December in the year of the competition.

Junior Men and Women: Any athlete of 18 or 19 years on 31st December in the year of the competition.

Master Men and Women: Any athlete who has reached his/her 35th birthday.

Note (i): All other matters concerning Masters' competitions are

referred to the IAAF/WMA Handbook approved by the IAAF and WMA Councils.

Note (ii): Eligibility, including minimum ages for participation in IAAF Competitions, shall be subject to the specific Technical Regulations.

RULE 142

Entries

1. Competitions under IAAF Rules are restricted to eligible athletes (See Chapter 2).
2. No athlete shall be allowed to compete outside his own country unless his eligibility is guaranteed by his Member Federation from whom he has permission to compete. In all International Competitions, such guarantee of eligibility of an athlete shall be accepted unless an objection as to his status is made to the Technical Delegate(s) (See also Rule 146.1).

Simultaneous Entries

3. If an athlete is entered in both a track and field event, or in more than one field event taking place simultaneously, the appropriate Referee may, for one round at a time, or for each trial in the High Jump and Pole Vault, allow an athlete to take his trial in an order different from that decided upon by the draw prior to the start of the competition. However, if an athlete subsequently is not present for any trial, it shall be deemed that he is passing once the period allowed for the trial has elapsed. In the case of the High Jump and Pole Vault, if an athlete is not present when all other athletes who are present have completed the competition, the Referee shall deem that such athlete(s) has abandoned the competition, once the period for one further trial has elapsed.

Failure to participate

4. At all competitions under Rules 1.1(a), (b), (c) and (f), except as provided below, an athlete shall be excluded from participation in all further events in the competition, including relays, in cases where:
 - (a) a final confirmation was given that the athlete would start in an event but then failed to participate;
 - (b) he qualified in preliminaries or heats for further participation in an event but then failed to participate further.The provision of a medical certificate, endorsed by a medical officer appointed or approved by the IAAF and/or the Organising

Committee, may be accepted as sufficient reason to accept that the athlete became unable to compete after confirmations closed or after competing in a previous round but will be able to compete in further events on a subsequent day of the competition. Other justifiable reasons (e.g. factors independent of the athlete's own actions, such as problems with the official transport system) may, after confirmation, also be accepted by the Technical Delegate(s).

Note (i): A fixed time for the final confirmation of participation shall be published in advance.

Note (ii): Failure to participate includes failure to compete honestly with bona fide effort. The relevant Referee will decide on this and the corresponding reference must be made in the official results. The situation foreseen in this Note will not apply to combined events individual events.

RULE 143

Clothing, Shoes and Number Bibs

Clothing

1. In all events athletes must wear clothing which is clean, and designed and worn so as not to be objectionable. The clothing must be made of a material which is non-transparent even if wet. Athletes must not wear clothing which could impede the view of the Judges. Athletes' vests should have the same colour on the front and back.

At all competitions under Rules 1.1(a) to (f), athletes shall participate in the uniform clothing approved by their National Governing Body. At all competitions under Rules 1.1(c), (d), (e), (h), (i) and (j), athletes shall participate in national uniform clothing or in club clothing officially approved by their National Governing Body. The Victory Ceremony and any lap of honour are considered part of the competition for this purpose.

Shoes

2. Athletes may compete barefoot or with footwear on one or both feet. The purpose of shoes for competition is to give protection and stability to the feet and a firm grip on the ground. Such shoes, however, must not be constructed so as to give an athlete any unfair additional assistance, including by the incorporation of any technology which will give the wearer any unfair advantage. A shoe strap over the instep is permitted. All types of competition shoes must be approved by IAAF.

Number of Spikes

3. The sole and heel of the shoes shall be so constructed as to provide for the use of up to 11 spikes. Any number of spikes up to 11 may be used but the number of spike positions shall not exceed 11.

Dimensions of Spikes

4. When a competition is conducted on a synthetic surface, that part of each spike which projects from the sole or the heel shall not exceed 9mm except in the High Jump and Javelin Throw, where it shall not exceed 12mm. The spike must be so constructed that it will, at least for the half of its length closest to the tip, fit through a square sided 4mm gauge.

The Sole and the Heel

5. The sole and/or heel may have grooves, ridges, indentations or protuberances, provided these features are constructed of the same or similar material to the basic sole itself.

In the High Jump and Long Jump, the sole shall have a maximum thickness of 13mm and the heel in high jump shall have a maximum thickness of 19mm. In all other events the sole and/or heel may be of any thickness.

Note: The thickness of the sole and heel shall be measured as the distance between the inside top side and the outside under side, including the above-mentioned features and including any kind or form of loose inner sole.

Inserts and Additions to the Shoe

6. Athletes may not use any appliance, either inside or outside the shoe, which will have the effect of increasing the thickness of the sole above the permitted maximum, or which can give the wearer any advantage which he would not obtain from the type of shoe described in the previous paragraphs.

Number bibs

7. Every athlete shall be provided with two number bibs which, during the competition, shall be worn visibly on the breast and back, except in the High Jump and Pole Vault, where one number bib may be worn on the breast or back only. The number bib shall correspond with the number allocated to the athlete in the programme. If track suits are worn during the competition, number bibs shall be worn on the track suit in a similar manner. In competitions under 1.1(d) to (j), either the athletes' names or other suitable identification on the bibs will be allowed.

8. These number bibs must be worn as issued and may not be cut, folded or obscured in any way. In long distance events these number bibs may be perforated to assist the circulation of air, but the perforation must not be made on any of the lettering or numerals which appear on them.
9. Where Photo Finish System is in operation, the Organising Committee may require athletes to wear additional number identification of an adhesive type on the side of their shorts. No athlete shall be allowed to take part in any competition without displaying the appropriate number bib(s) and/or identification.

RULE 144

Assistance to Athletes

Indication of Intermediate Times

1. Intermediate times and preliminary winning times may be officially announced and/or displayed. Otherwise such times must not be communicated to the athletes by persons in the competition area without the prior approval of the appropriate Referee.

Giving Assistance

2. The following shall not be considered assistance:
 - (a) Communication between the athletes and their coaches not placed in the competition area. In order to facilitate this communication and not to disturb the staging of the competition, a place in the stands, close to the immediate site of each field event, should be reserved to the athletes' coaches.
 - (b) Medical examination / treatment and/or physiotherapy necessary to enable an athlete to participate or continue participation once on the competition area. Such medical examination / treatment and/or physiotherapy may be provided either on the competition area itself by the official medical staff appointed by the Organising Committee and identified by armbands, vests or similar distinctive apparel or in designated medical treatment areas outside the competition area by accredited team medical personnel specifically approved by the Medical or Technical Delegate for the purpose. In neither case shall the intervention delay the conduct of the competition or an athlete's trial in the designated order. Such attendance or assistance by any other person whether during competition or immediately before

competition once athletes have left the Call Room is assistance.

For the purpose of this Rule the following shall be considered assistance, and are therefore not allowed:

- (c) pacing in races by persons not participating in the same race, by athletes lapped or about to be lapped or by any kind of technical device.
- (d) possession or use of video or cassette recorders, radios, CD, radio transmitters, mobile phone or similar devices in the arena.
- (e) use of any technical device that incorporates springs, wheels or any other element that provides the user with an advantage over another athlete not using such a device.
- (f) use of any appliance that has the effect of increasing the dimension of a piece of equipment beyond the permitted maximum in the Rules or that provides the user with an advantage which he would not have obtained using the equipment specified in the Rules.

Any athlete giving or receiving assistance from within the competition area during an event shall be warned by the Referee and advised that, if there is any repetition, he will be disqualified from that event. If an athlete is subsequently disqualified from the event, any performance accomplished up to that time in the same round of that event shall not be considered valid. However, performances accomplished in a previous qualifying round of that event shall be considered valid.

Wind Information

- 3. A wind sock should be placed in an appropriate position in all jumping events, Discus Throw and Javelin Throw, to show the athletes the approximate direction and strength of the wind.

Drinking/Sponging

- 4. In track events of 5000m or longer, the Organising Committee may provide water and sponges to athletes if weather conditions warrant such provision.

RULE 145
Disqualification

- 1. If an athlete is disqualified in an event for an infringement of a technical Rule, reference shall be made in the official results to the Rule which has been infringed. Any performance

accomplished in the same round of that event up to the time of the disqualification shall not be considered valid. However, performances accomplished in a previous qualifying round of that event shall be considered valid. Disqualification from an event for an infringement of the technical Rules shall not prevent an athlete from taking part in any further event in that competition.

2. If an athlete is disqualified from an event for acting in an unsporting or improper manner, reference shall be made in the official results giving reasons for such disqualification. If an athlete is warned for a second time under Rule 125.5 for acting in an unsporting or improper manner in an event, he shall be disqualified from that event. If the athlete's second warning occurs in a different event, he shall be disqualified only from the second event. Any performance accomplished in the same round of that event up to the time of the disqualification shall not be considered valid. However, performances accomplished in a previous qualifying round of that event, other previous events or previous individual events of a Combined Event shall be considered valid. Disqualification from an event for unsporting or improper behaviour shall render the athlete liable to disqualification by the Referee from participation in all further events in that competition. If the offence is considered serious, the Competition Director shall report it to the appropriate governing body for consideration of further disciplinary action according to Rule 22.1(f).

RULE 146

Protests and Appeals

1. Protests concerning the status of an athlete to participate in a competition must be made, prior to the commencement of such competition, to the Technical Delegate(s). Once the Technical Delegate(s) make a decision, there shall be a right of appeal to the Jury of Appeal. If the matter cannot be settled satisfactorily prior to the competition, the athlete shall be allowed to compete "under protest" and the matter be referred to the Council of the IAAF.
2. Protests concerning the result or conduct of an event shall be made within 30 minutes of the official announcement of the result of that event.

The Organising Committee of the competition shall be responsible for ensuring that the time of the announcement of all results is recorded.

3. Any protest shall, in the first instance, be made orally to the Referee by the athlete himself or by someone acting on his behalf. To arrive at a fair decision, the Referee should consider any available evidence which he thinks necessary, including a film or picture produced by an official video tape recorder, or any other available video evidence. The Referee may decide on the protest or may refer the matter to the Jury. If the Referee makes a decision, there shall be a right of appeal to the Jury.
4. (a) In a track event, if an athlete makes an immediate oral protest against having been charged with a false start, a Track Referee may allow the athlete to compete under protest in order to preserve the rights of all concerned. Such a protest cannot be accepted if the false start was detected by an IAAF approved false start control apparatus, unless for any reason the Referee determines that the information provided by the apparatus is obviously inaccurate.
Where an IAAF approved false start control apparatus is used, a protest may be based on the failure of the Starter to recall a false start. The protest may be made only by, or on behalf of, an athlete who has completed the race. If the protest is upheld, any athlete who committed the false start, and who was subject to disqualification according to Rule 162.7, shall be disqualified. Where there is no disqualification of any athlete according to Rule 162.7, the Referee shall have the authority to declare the event void and that it shall be held again if in his opinion justice demands it.
Note: The right of protest and appeal shall apply whether or not a false start control apparatus is used.
- (b) In a Field Event, if an athlete makes an immediate oral protest against having a trial judged as a failure, the Referee of the event may, at his discretion, order that the trial be measured and the result recorded, in order to preserve the rights of all concerned.
If the protested trial occurred during the first three rounds of trials of an event in which more than eight athletes are competing, and the athlete would advance to the final three rounds only if the protest was upheld, the Referee may allow the athlete to compete in the final three rounds under protest in order to preserve the rights of all concerned.
5. An appeal to the Jury of Appeal must be made within 30 minutes of the official announcement of the decision made by the Referee, in writing, signed by a responsible official on behalf of the

athlete, and shall be accompanied by a deposit of USD100, or its equivalent, which will be forfeited if the appeal is not allowed.

6. The Jury of Appeal shall consult all relevant persons. If the Jury of Appeal is in doubt, other available evidence may be considered. If such evidence, including any available video evidence, is not conclusive, the decision of the Referee shall be upheld.
7. The decision of the Jury of Appeal (or, in the absence of a Jury of Appeal, the decision of the Referee) shall be final. There shall be no further right of appeal, including to the Court of Arbitration for Sport.

RULE 147

Mixed Competition

For all competitions held completely in the stadium, mixed events between male and female participants shall not normally be permitted. However, mixed stadium competition in Field Events and in races of 5000m or longer may be permitted in all competitions except those held under Rules 1.1(a) to (h). In the case of competitions held under Rules 1.1(i) and (j) such mixed competition shall be allowed in a particular competition if specifically permitted by the relevant area or national governing body.

RULE 148

Measurements

For track and field events in competitions under Rules 1.1(a), (b), (c) and (f), all measurements shall be made with a calibrated certified steel tape or bar or with a scientific measuring device. The steel tape, bar or scientific measuring device shall have been certified by the IAAF and the accuracy of the measuring equipment used in the competition shall have been verified by an appropriate organisation accredited by the national measurement authority, such that all measurements can be traced back to national and international measurement standards.

At competitions other than those held under Rules 1.1(a), (b), (c) and (f), fibreglass tapes may also be used.

Note: Concerning acceptance of Records, see Rule 260.26 (a).

RULE 149

Validity of Performances

No performance accomplished by an athlete will be valid unless it is

accomplished during an official competition organised in conformity with IAAF Rules.

RULE 150

Video Recording

In competitions held under Rules 1.1(a), (b) and (c) and, whenever possible, in other competitions, it is recommended that an official video recording of all events on which the accuracy of performances and violation of the Rules are recorded, be used as supporting documentation.

RULE 151

Scoring

In a match where the result is to be determined by the scoring of points, the method of scoring shall be agreed by all the competing countries before the start of the match.

SECTION III - TRACK EVENTS

Rules 163.2, 163.6 (except under Rules 230.11 and 240.10), 164.2 and 165 also apply to Sections VII, VIII, and IX.

RULE 160

Track Measurements

1. The length of a standard running track shall be 400m. It shall consist of two parallel straights and two bends whose radii shall be equal. The inside of the track shall be bordered by a kerb of suitable material, approximately 5cm in height and minimum 5cm in width.

If a section of the kerb has to be temporarily removed for field events, its place shall be marked with a white line 5cm in width and by cones or flags, minimum height 20cm, placed on the white line so that the edge of the base of the cone or flag pole coincides with the edge of the white line closest to the track, and placed at intervals not exceeding 4m to prevent any athlete running on the line. (Flags shall be placed at an angle of 60° with the ground away from the track.) This shall also apply to the section of the steeplechase track where athletes divert from the main track to negotiate the water jump.

2. The measurement shall be taken 30cm outward from the kerb or, where no kerb exists, 20cm from the line marking the inside of the track.

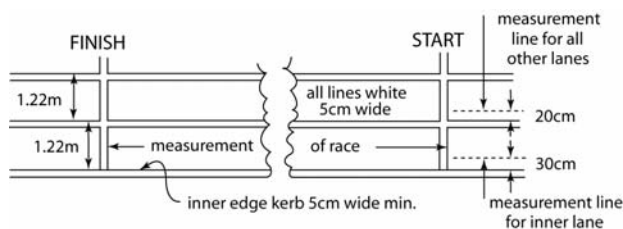

Figure 1 - Track measurements (infield view)

3. The distance of the race shall be measured from the edge of the start line farther from the finish to the edge of the finish line nearer to the start.

4. In all races up to and including 400m, each athlete shall have a separate lane, with a width of $1.22\text{m} \pm 0.01\text{m}$ marked by white lines 5cm in width. All lanes shall be the same width. The inner lane shall be measured as stated in Rule 160.2, but the remaining lanes shall be measured 20cm from the outer edges of the lines.
Note (i): For all tracks constructed before 1 January 2004 for all such races, the lane may have a width of maximum 1.25m.
Note (ii): The line on the right hand of each lane shall be included in the measurement of the width of each lane (see Rules 163.3 and 163.4).
5. In International Competitions under Rules 1.1(a), (b), (c) and (f), the track should allow for eight lanes.
6. The lateral inclination of tracks should not exceed 1:100 and the overall inclination in the running direction shall not exceed 1:1000 downwards.
Note: It is recommended that, for new tracks, the lateral inclination should be towards the inside lane.
7. Full technical information on track construction, layout and marking is contained in the IAAF Track and Field Facilities Manual. This Rule gives basic principles, which must be followed.

RULE 161
Starting Blocks

1. Starting blocks shall be used for all races up to and including 400m (including the first leg of the 4x200m and 4x400m) and shall not be used for any other race. When in position on the track, no part of the starting block shall overlap the start line or extend into another lane.
Starting blocks shall comply with the following general specifications:
 - (a) They shall be entirely rigid in construction and shall give no unfair advantage to the athlete.
 - (b) They shall be fixed to the track by a number of pins or spikes, arranged to cause the minimum possible damage to the track. The arrangement shall permit the starting blocks to be quickly and easily removed. The number, thickness and length of pins or spikes depend on the track construction. The anchorage shall permit no movement during the actual start.
 - (c) When an athlete uses his own starting blocks, they shall comply with Rules 161(a) and (b). They may be of any

design or construction, provided that they do not interfere with other athletes.

- (d) When starting blocks are provided by the Organising Committee, they shall, in addition, comply with the following specifications:

The starting blocks shall consist of two foot plates, against which the athlete's feet are pressed in the starting position. The foot plates shall be mounted on a rigid frame, which shall in no way obstruct the athlete's feet as they leave the blocks. The foot plates shall be sloped to suit the starting position of the athlete, and may be flat or slightly concave. The surface of the foot plates shall accommodate the spikes in the athlete's shoes, either by using slots or recesses in the face of the foot plate or by covering the surface of the foot plate with suitable material permitting the use of spiked shoes.

The mounting of the foot plates on a rigid frame may be adjustable, but it shall allow no movement during the actual start. In all cases, the foot plates shall be adjustable forward or backward in relation to each other. The adjustments shall be secured by firm clamps or a locking mechanism, which can be easily and quickly operated by the athlete.

2. In competitions held under Rules 1.1(a), (b), (c) and (f) the starting blocks shall be linked to an IAAF approved false start control apparatus. The Starter and/or an assigned Recaller shall wear headphones in order to clearly hear the acoustic signal emitted when the apparatus detects a false start (i.e. when reaction time is less than 100/1000ths of a second). As soon as the Starter and/or an assigned Recaller hears the acoustic signal, and if the gun is fired, or the approved starting apparatus is activated, there shall be a recall and the Starter shall immediately examine the reaction times on the false start control apparatus in order to confirm which athlete(s) is/are responsible for the false start. This system is strongly recommended for all other competitions.
3. In competitions held under Rules 1.1(a) to (f), athletes shall use starting blocks provided by the Organising Committee of the competition. In other competitions, on synthetic surfaced tracks the Organising Committee may insist that only starting blocks provided by them may be used.

RULE 162
The Start

1. The start of a race shall be denoted by a white line 5cm wide. In all races not run in lanes the start line shall be curved, so that all the athletes start the same distance from the finish. Stations in events at all distances shall be numbered from left to right, facing the direction of running.
2. All races shall be started by the report of the Starter's gun or approved starting apparatus fired upwards after he has ascertained that athletes are steady and in the correct starting position.
3. At all International Competitions, except as noted below, the commands of the Starter in his own language, in English or in French shall, in races up to and including 400m (including 4x200m and 4x400m), be "On your marks" and "Set". When all athletes are "Set", the gun shall be fired, or approved starting apparatus activated. An athlete shall not touch either the start line or the ground in front of it with his hands or his feet when on his marks.
In races longer than 400m, the command shall be "On your marks" and when all athletes are steady, the gun shall be fired, or approved starting apparatus activated. An athlete shall not touch the ground with his hand or hands during the start.
Note: In competitions under Rules 1.1(a), (b) and (c), the commands of the Starter shall be given in English only.
4. If for any reason the Starter is not satisfied that all is ready for the start to proceed after the athletes are on their marks, he shall order all athletes to withdraw from their marks and the Starter's Assistants shall place them on the assembly line again.
In all races up to and including 400m (including the first leg of the 4x200m and 4x400m), a crouch start and the use of starting blocks are compulsory.
After the "On your marks" command, an athlete shall approach the start line, assume a position completely within his allocated lane and behind the start line. Both hands and at least one knee shall be in contact with the ground and both feet in contact with the starting blocks. At the "Set" command, an athlete should immediately rise to his final starting position retaining the contact of the hands with the ground and of the feet with the foot plates of the blocks.
5. On the command "On your marks" or "Set", as the case may be, all athletes shall at once and without delay assume their full and final set position.

When an athlete, after the command "On your marks" or "Set", and before the report of the gun or approved starting apparatus, causes the start to be aborted, for instance by raising a hand and/or standing in the case of a crouch start, without a valid reason, (such reason to be evaluated by the relevant Referee), the Referee will warn him for improper conduct.

Note: In this case, as well as when an extraneous reason was considered to be the cause for aborting the start, a green card shall be shown to all the athletes to indicate that a false start was not committed.

False start

6. An athlete, after assuming a full and final set position, shall not commence his starting motion until after receiving the report of the gun, or approved starting apparatus. If, in the judgement of the Starter or Recallers, he does so any earlier, it shall be deemed a false start.

It shall also be deemed a false start if, in the judgement of the Starter:

- (a) an athlete fails to comply with the commands "On your marks" or "Set" as appropriate after a reasonable time.
- (b) an athlete after the command "on your marks" disturbs other athletes in the race through sound or otherwise.

Note: When an IAAF approved false start control apparatus is in operation (see Rule 161.2 for operational details of equipment), the evidence of this equipment shall normally be accepted as conclusive by the Starter.

7. Any athlete making a false start shall be warned. Except in Combined Events, only one false start per race shall be allowed without the disqualification of the athlete(s) making the false start. Any athlete(s) making further false starts in the race shall be disqualified from the race.

In Combined Events, if an athlete is responsible for two false starts, he shall be disqualified.

Note: In practice, when one or more athletes make a false start, others are inclined to follow and, strictly speaking, any athlete who does so has also made a false start. The Starter should warn or disqualify only such athlete or athletes who, in his opinion, were responsible for the false start. This may result in more than one athlete being warned or disqualified. If the false start is not due to any athlete, no warnings shall be given and a green card shall be shown to all the athletes.

8. The Starter or any Recaller, who is of the opinion that the start was not a fair one, shall recall the athletes by firing a gun.

1000m, 2000m, 3000m, 5000m and 10,000m

9. When there are more than 12 athletes in a race, they may be divided into two groups with one group of approximately 65% of the athletes on the regular arced start line and the other group on a separate arced start line marked across the outer half of the track. The other group should run as far as the end of the first bend on the outer half of the track.

The separate arced start line shall be positioned in such a way that all the athletes shall run the same distance.

The breakline for 800m described in Rule 163.5 indicates where the athletes in the outer group in 2000m and 10,000m may join the athletes using regular start. The track shall be marked at the entrance to the finish straight for group starts in 1000m, 3000m and 5000m to indicate where athletes starting in the outer group may join the athletes using the regular start. This mark may be a 5cmx5cm mark on the line between lanes 4 and 5 (lanes 3 and 4 in a six-lane track) on which a cone or flag is placed until the two groups converge.

RULE 163

The Race

-
1. The direction of running and walking shall be left-hand inside. The lanes shall be numbered with the left-hand inside lane numbered 1.

Obstruction

2. Any competing athlete who jostles or obstructs another athlete, so as to impede his progress, shall be liable to disqualification from that event. The Referee shall have the authority to order the race to be re-held excluding any disqualified athlete or, in the case of a heat, to permit any athlete(s) seriously affected by jostling or obstruction (other than any disqualified athlete), to compete in a subsequent round of the event. Normally such an athlete should have completed the event with bona fide effort.

Regardless of whether there has been a disqualification, the Referee, in exceptional circumstances, shall also have the authority to order the race to be re-held if he considers it just and reasonable to do so.

Running in Lanes

3. In all races run in lanes, each athlete shall keep within his

allocated lane from start to finish.

This shall also apply to any portion of a race run in lanes and in a race (or any part of the race) not run in lanes, when an athlete runs on a bend, on or inside the line (or kerb) marking the inside of the track (including on the diversion from the track for the steeplechase water jump).

Except as stated in 163.4, if the Referee is satisfied, on the report of a Judge or Umpire or otherwise, that an athlete has run outside his lane, he shall be disqualified.

4. If an athlete is pushed or forced by another person to run outside his lane, and if no material advantage is gained, the athlete shall not be disqualified.

If an athlete either:

- (a) runs outside his lane in the straight, and no material advantage is gained or
 - (b) runs outside the outer line of his lane on the bend, with no material advantage thereby being gained,
- and no other athlete is obstructed then he shall likewise not be disqualified.

5. In competitions held under Rules 1.1(a), (b), (c) and (f), the 800m event shall be run in lanes as far as the nearer edge of the breakline marked after the first bend where athletes may leave their respective lanes.

The breakline shall be an arced line, 5cm wide, across the track. To assist athletes identify the breakline, small cones or prisms, 5cmx5cm and no more than 15cm high, preferably of different colour from the breakline and the lane lines, shall be placed on the lane lines immediately before the intersection of the lane lines and the breakline.

Note: In international matches, countries may agree not to use lanes.

Leaving the Track

6. An athlete, after voluntarily leaving the track, shall not be allowed to continue in the race.

Check-Marks

7. Except when all or the first portion of a relay race is being run in lanes, athletes may not make check-marks or place objects on or alongside the running track for their assistance.

Wind Measurement

8. The periods for which the wind velocity shall be measured from

the flash of the Starter's gun or approved starting apparatus are as follows:

	Seconds
100m	10
100m Hurdles	13
110m Hurdles	13

In the 200m event, the wind velocity shall be measured for a period of 10 seconds commencing when the first athlete enters the straight.

9. The wind gauge for track events shall be placed beside the straight, adjacent to lane 1, 50m from the finish line. It shall be positioned 1.22m high and not more than 2m away from the track.
10. The wind gauge shall be read in metres per second, rounded to the next higher tenth of a metre per second, in the positive direction (that is, a reading of +2.03 metres per second shall be recorded as +2.1; a reading of -2.03 metres per second shall be recorded as -2.0). Gauges that produce digital readings expressed in tenths of metres per second shall be constructed so as to comply with this Rule.

All wind gauge equipment shall have been certified by the IAAF and the accuracy of the gauge used shall have been verified by an appropriate organisation accredited by the national measurement authority, such that all measurements can be traced back to national and international measurement standards.

11. Ultrasonic wind gauges shall be used at all International Competitions under Rules 1.1(a) to (h).
A mechanical wind gauge should have appropriate protection to reduce the impact of any crosswind. Where tubes are used, their length on either side of the measuring device should be at least twice the diameter of the tube.
12. The wind gauge may be started and stopped automatically and/or remotely, and the information conveyed directly to the competition computer.

RULE 164 **The Finish**

1. The finish of a race shall be denoted by a white line 5cm wide.
2. The athletes shall be placed in the order in which any part of their bodies (i.e. torso, as distinguished from the head, neck, arms,

legs, hands or feet) reaches the vertical plane of the nearer edge of the finish line as defined above.

3. In any race decided on the basis of the distance covered in a fixed period of time, the Starter shall fire the gun exactly one minute before the end of the race to warn athletes and Judges that the race is nearing its end. The Starter shall be directed by the Chief Timekeeper and, at exactly the appropriate time after the start, he shall signal the end of the race by again firing the gun. At the moment the gun is fired to signal the end of the race, the Judges appointed for that purpose shall mark the exact spot where each athlete touched the track for the last time before or simultaneously with the firing of the gun.

The distance achieved shall be measured to the nearest metre behind this mark. At least one Judge shall be assigned to each athlete before the start of the race for the purpose of marking the distance achieved.

RULE 165

Timing and Photo Finish

1. Three alternative methods of timekeeping shall be recognised as official:
 - (a) Hand Timing;
 - (b) Fully Automatic Timing obtained from a Photo Finish System;
 - (c) Timing provided by a Transponder System for competitions held under Rules 230 (races not held completely in the stadium), 240 and 250 only.
2. The time shall be taken to the moment at which any part of the body of an athlete (i.e. torso, as distinguished from the head, neck, arms, legs, hands or feet) reaches the vertical plane of the nearer edge of the finish line.
3. Times for all finishers shall be recorded. In addition, whenever possible, lap times in races of 800m and over and intermediate times at every 1000m in races of 3000m and over shall be recorded.

Hand timing

4. The Timekeepers shall be in line with the finish and where possible, they should be placed at least 5m from the outside lane of the track. In order that they may all have a good view of the finish line, an elevated stand should be provided.
5. Timekeepers shall use either stopwatches or manually

operated electronic timers with digital readouts. All such timing devices are termed "watches" for the purpose of the Rules.

6. The lap and intermediate times as per Rule 165.3 shall be recorded either, by designated members of the timekeeping team using watches capable of taking more than one time, or by additional Timekeepers.
7. The time shall be taken from the flash / smoke of the gun or approved starting apparatus.
8. Three official Timekeepers (one of whom shall be the Chief Timekeeper) and one or two additional Timekeepers shall time the winner of every event. The times recorded by the additional Timekeepers' watches shall not be considered unless one or more of the official Timekeepers' watches fail to record the time correctly, in which case the additional Timekeepers shall be called upon, in such order as has been decided previously, so that in all the races, three watches should have recorded the official winning time.
9. Each Timekeeper shall act independently and without showing his watch to, or discussing his time with, any other person, shall enter his time on the official form and, after signing it, hand it to the Chief Timekeeper who may examine the watches to verify the reported times.
10. For all hand-timed races on the track, the time shall be read and recorded to the next longer 1/10th of a second. The times for races partly or entirely outside the stadium shall be converted and recorded to the next longer whole second, e.g. for the Marathon 2:09:44.3 shall be recorded as 2:09:45.
If the hand of the watch stops between two lines indicating the time, the longer time shall be accepted. If a 1/100th second watch or an electronic manually operated digital timer is used, all times not ending in zero in the second decimal shall be converted and recorded to the next longer 1/10th of a second, e.g. 10.11 shall be recorded as 10.2.
11. If two of the three watches agree and the third disagrees, the time recorded by the two shall be the official time. If all three watches disagree, the middle time shall be official. If only two times are available and they disagree, the longer time shall be official.
12. The Chief Timekeeper, acting in accordance with the Rules mentioned above, shall decide the official time for each athlete and provide the result to the Competition Secretary for distribution.

Fully Automatic Timing and Photo Finish System

13. Fully Automatic Timing and Photo Finish System approved by IAAF should be used at all competitions.

The system

14. The System shall be approved by the IAAF, based upon a test of accuracy made within 4 years prior to the competition. It shall be started automatically by the Starter's gun, or approved starting apparatus, so that the overall delay between the report from the muzzle and the start of the timing system is constant and less than 1/1000th of a second.

15. A system which operates automatically at either the start or the finish, but not at both, shall be considered to produce neither Hand nor Fully Automatic Times and shall not therefore be used to obtain official times. In this case, the times read on the image will not, under any circumstances, be considered as official, but the image may be used as a valid support in order to determine placings and adjust time intervals between athletes.

Note: If the timing mechanism is not started by the Starter's gun, or approved starting apparatus, the time-scale on the image shall indicate this fact automatically.

16. The System must record the finish through a camera with a vertical slit, positioned in the extension of the finish line, producing a continuous image. The image must also be synchronised with a uniformly marked time-scale graduated in 1/100th of a second.

In order to confirm that the camera is correctly aligned and to facilitate the reading of the Photo Finish image, the intersection of the lane lines and the finish line shall be coloured black in a suitable design. Any such design must be solely confined to the intersection, for no more than 2cm beyond, and not extended before, the leading edge of the finish line.

17. The times and places of the athletes shall be read from the image by means of a cursor with its reading line guaranteed to be perpendicular to the time scale.
18. The System must automatically record the finish times of the athletes and must be able to produce a printed image which shows the time of every athlete.

Operation

19. The Chief Photo Finish Judge shall be responsible for the functioning of the System. Before the start of the competition, he will meet the technical staff involved and familiarise himself with

the equipment. In cooperation with the Referee for track events and the Starter, he shall initiate a control, before the beginning of each session, to ensure that the equipment is started automatically by the Starter's gun or approved starting apparatus, and is correctly aligned. He shall supervise the positioning and testing of the equipment and the zero control operation.

20. If possible, there should be at least two photo finish cameras in action, one from each side. Preferably, these timing systems should be technically independent, i.e. with different power supplies and recording and relaying the report of the Starter's gun, or approved starting apparatus, by separate equipment and cables.
Note: Where two or more Photo Finish cameras are used, one should be designated as official by the Technical Delegate (or International Photo Finish Judge where appointed) before the start of the competition. The times and places from the images of the other camera(s) should not be considered unless there is reason to doubt the accuracy of the official camera or if there is need to use the supplementary images to resolve uncertainties in the finishing order (i.e. athletes wholly or partially obscured on the image from the official camera).
21. In conjunction with the two Assistants, the Chief Photo Finish Judge shall determine the times of the athletes and their respective places. He shall ensure that these results are correctly entered in the competition results system and conveyed to the Competition Secretary.
22. Times from Photo Finish System shall be regarded as official unless for any reason the appropriate official decides that they obviously must be inaccurate. If such is the case, the times of the back-up Timekeepers, if possible adjusted based on information on time intervals obtained from the Photo Finish image, shall be official. Such back-up Timekeepers must be appointed where any possibility exists of failure of the timing system.
23. Times shall be read and recorded from the Photo Finish image as follow:
 - (a) For all races up to and including 10,000m, the time shall be read and recorded to 1/100th of a second. Unless the time is an exact 1/100th of a second, it shall be read and recorded to the next longer 1/100th of a second.
 - (b) For all races on the track longer than 10,000m, the time shall be read to 1/100th of a second and recorded to 1/10th of a second. All read times not ending in zero shall be converted and recorded to the next longer 1/10th of a second, e.g. for

20,000m, 59:26.32 shall be recorded as 59:26.4.

- (c) For all races held partly or entirely outside the stadium, the time shall be read to 1/100th of a second and recorded to the whole second. All read times not ending in two zeroes shall be converted and recorded to the next longer whole second, e.g. for the Marathon, 2:09:44.32 shall be recorded as 2:09:45.

Transponder System

24. The use of Transponder Timing Systems approved by IAAF in events held under Rules 230 (races not held completely in the stadium), 240 and 250 is permitted provided that:

- (a) None of the equipment used at the start, along the course or at the finish line constitutes a significant obstacle or barrier to the progress of an athlete.
- (b) The weight of the transponder and its housing carried on the athletes' uniform, number bib or shoe is not significant.
- (c) The System is started by the Starter's gun or approved starting apparatus.
- (d) The System requires no action by an athlete during the competition, at the finish or at any stage in the result processing.
- (e) The resolution is 1/10th of a second (i.e. it can separate athletes finishing 1/10th of a second apart). For all races, the time shall be read to 1/10th of a second and recorded to the whole second. All read times not ending in zero shall be converted and recorded to the next longer whole second, e.g. for the Marathon, 2:09:44.3 shall be recorded as 2:09:45.

Note: The official time shall be the time elapsed between the firing of the starting gun and the athlete reaching the finish line. However, the time elapsed between an athlete crossing the start line and the finish line can be made known to him, but will not be considered an official time.

- (f) Whilst the determination of the finishing order and times may be considered official, Rules 164.2 and 165.2 may be applied where necessary.

Note: It is recommended that judges and/or video recording(s) also be provided to assist in determining the finishing order.

RULE 166

Seedings, Draws and Qualification in Track Events**Rounds and Heats**

1. Preliminary rounds (heats) shall be held in Track Events in which the number of athletes is too large to allow the competition to be conducted satisfactorily in a single round (final). Where preliminary rounds are held, all athletes must compete in, and qualify through, all such rounds.
2. The heats, quarter-finals and semi-finals shall be arranged by the appointed Technical Delegates. If no Technical Delegates have been appointed they shall be arranged by the Organising Committee.

The following tables shall, in the absence of extraordinary circumstances, be used to determine the number of rounds, and the number of heats in each round, to be held and the qualification procedure for each round of track events:

100m, 200m, 400m, 100m H, 110m H, 400m H

Declared R3	Qualifying R1			Qualifying R2			Qualifying	
Entries	Heats	P	T	Heats	P	T	Heats	P T
9-16	2	3	2					
17-24	3	2	2					
25-32	4	3	4	2	3	2		
33-40	5	4	4	3	2	2		
41-48	6	3	6	3	2	2		
49-56	7	3	3	3	2	2		
57-64	8	3	8	4	3	4	2	4
65-72	9	3	5	4	3	4	2	4
73-80	10	3	2	4	3	4	2	4
81-88	11	3	7	5	3	1	2	4
89-96	12	3	4	5	3	1	2	4
97-104	13	3	9	6	3	6	3	2 2
105-112	14	3	6	6	3	6	3	2 2

800m, 4x100m, 4x400m

Declared R3	Qualifying R1			Qualifying R2			Qualifying	
Entries	Heats	P	T	Heats	P	T	Heats	P
9-16	2	3	2					
17-24	3	2	2					
25-32	4	3	4	2	3	2		
33-40	5	4	4	3	2	2		

41-48	6	3	6	3	2	2		
49-56	7	3	3	3	2	2		
57-64	8	2	8	3	2	2		
65-72	9	3	5	4	3	4	3	2 2
73-80	10	3	2	4	3	4	3	2 2
81-88	11	3	7	5	3	1	3	2 2
89-96	12	3	4	5	3	1	3	2 2
97-104	13	3	9	6	3	6	3	2 2
105-112	14	3	6	6	3	6	3	2 2

1500m, 3000m, 3000m SC

Declared	Qualifying R1		Qualifying R2	
Entries	Heats P	T	Heats P	T
16-30	2	4	4	
31-45	3	6	6	2 5 2
46-60	4	5	4	2 5 2
61-75	5	4	4	2 5 2

5000m

Declared	Qualifying R1		Qualifying R2	
Entries	Heats P	T	Heats P	T
20-40	2	5	5	
41-60	3	8	6	2 6 3
61-80	4	6	6	2 6 3
81-100	5	5	5	2 6 3

10,000m

Declared	Qualifying R1	
Entries	Heats P	T
28-54	2	8 4
55-81	3	5 5
82-108	4	4 4

Whenever possible, representatives of each nation or team shall be placed in different heats in all rounds of the competition.

Note (i): When heats are being arranged, it is recommended that as much information as possible about the performances of all athletes should be considered and the heats drawn so that, normally, the best performers reach the final.

Note (ii): For World Championships and Olympic Games, alternate tables may be included in the relevant Technical Regulations.

3. After the first round, the athletes shall be placed in the heats of subsequent rounds in accordance with the following procedures:
 - (a) for events of 100m to 400m inclusive, and relays up to and

including 4x400m, seeding shall be based upon placings and times of each previous round. For this purpose, athletes shall be ranked as follows:

Fastest heat winner
 2nd fastest heat winner
 3rd fastest heat winner, etc.
 Fastest 2nd place
 2nd fastest 2nd place
 3rd fastest 2nd place, etc.
 (Concluding with)
 Fastest time qualifier
 2nd fastest time qualifier
 3rd fastest time qualifier, etc.

The athletes shall then be placed in heats in the order of seeding in a zigzag distribution, e.g. three heats will consist of the following seedings:

A	1	6	7	12	13	18	19	24
B	2	5	8	11	14	17	20	23
C	3	4	9	10	15	16	21	22

The order of running heats A, B, C shall be drawn.

(b) for other events, the original performance lists shall continue to be used for seeding, modified only by improvements in performances achieved during the earlier round(s).

For the first round, the athletes shall be placed in heats, and the order of heats drawn, using the above system, but with the seeding determined from the relevant list of valid performances achieved during the predetermined period.

4. For events 100m to 800m inclusive, and relays up to and including 4x400m, where there are several successive rounds of a race, lanes will be drawn as follows:

(a) In the first round the lane order shall be drawn by lot.
 (b) For the following rounds, athletes shall be ranked after each round in accordance with the procedure shown in Rule 166.3(a) or in the case of 800m, 166.3(b).

||

Three draws will then be made:

(c) one for the four highest ranked athletes or teams to determine placings in lanes 3, 4, 5 and 6;
 (d) another for the fifth and sixth ranked athletes or teams to determine placings in lanes 7 and 8, and
 (e) another for the two lowest ranked athletes or teams to

|||

||

determine placings in lanes 1 and 2.

Note (i): When there are fewer than 8 lanes, the above system with the necessary modifications should be followed.

Note (ii): In competitions under Rules 1.1(d) to (j), the 800m event may be run with one or two athletes in each lane, or with group start behind an arced line.

Note (iii): In competitions under Rules 1.1(a), (b), (c) and (f), this should normally be applied only in the first round, unless because of ties or advancement by the Referee, there are more athletes in a heat of a subsequent round than were anticipated.

5. An athlete shall not be allowed to compete in a heat other than the one in which his name appears, except in circumstances which, in the opinion of the Referee, justify an alteration.
6. In all preliminary rounds, at least the first and second places in each heat shall qualify for the next round and it is recommended that, where possible, at least three in each heat should qualify. Except where Rule 167 applies, any other athletes may qualify by place or by time according to Rule 166.2, the particular Technical Regulations, or as determined by the Technical Delegate(s). When athletes are qualified according to their times, only one system of timing may be applied. The order in which heats are to be run shall be determined by draw after the composition of the heats has been decided.
7. The following minimum times must be allowed, when practicable, between the last heat of any round and the first heat of a subsequent round or final:

Up to and including 200m	45 minutes
Over 200m up to and including 1000m	90 minutes
Over 1000m	Not on the same day

Single Rounds

8. In competitions under Rules 1.1(a), (b), (c) and (f), for events longer than 800m, relays longer than 4x400m and any event where only a single round (final) is required, lanes/starting positions shall be drawn by lot.

RULE 167

Ties

Ties shall be resolved as follows:

In determining whether there has been a tie in any round for a qualifying position for the next round based on time, the Chief Photo Finish Judge shall consider the actual time recorded by the athletes to

1/1000th of a second. If it is thus determined that there has been a tie, the tying athletes shall be placed in the next round or, if that is not practicable, lots shall be drawn to determine who shall be placed in the next round.

In the case of a tie for first place in any final, the Referee is empowered to decide whether it is practicable to arrange for the athletes so tying to compete again. If he decides it is not, the result will stand. Ties in other placings shall remain.

RULE 168
Hurdle Races

1. Distances. The following are the standard distances:

Men, Junior Men and Youth Boys: 110m, 400m
Women, Junior Women and Youth Girls: 100m, 400m

There shall be ten flights of hurdles in each lane, set out in accordance with the following table:

Men, Junior Men and Youth Boys

Distance of race	Distance from start line to first hurdle	Distance between hurdles	Distance from last hurdle to finish line
110m	13.72m	9.14m	14.02m
400m	45.00m	35.00m	40.00m

Women, Junior Women and Youth Girls

Distance of race	Distance from start line to first hurdle	Distance between hurdles	Distance from last hurdle to finish line
100m	13.00m	8.50m	10.50m
400m	45.00m	35.00m	40.00m

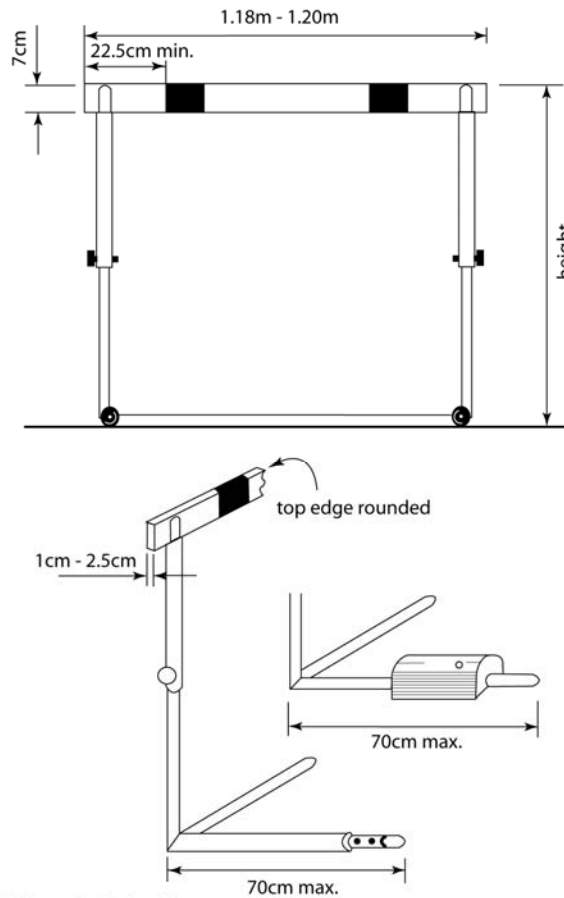

Figure 2 - Example of a hurdle

Each hurdle shall be so placed on the track that the feet shall be on the side of the approach by the athlete. The hurdle shall be so placed that the edge of the bar nearest the approaching hurdler coincides with the track marking nearest the athlete.

2. Construction. The hurdles shall be made of metal or some other suitable material with the top bar of wood or other suitable material. They shall consist of two feet and two uprights

supporting a rectangular frame, reinforced by one or more cross bars, the uprights to be fixed at the extreme end of each base. The hurdle shall be of such a design that a force at least equal to the weight of 3.6kg applied horizontally to the centre of the top edge of the top bar is required to overturn it. The hurdle may be adjustable in height for each event. The counterweights shall be adjustable so that at each height a force at least equal to the weight of 3.6kg and not more than 4kg is required to overturn it.

3. Dimensions. The standard heights of the hurdles shall be:

Distance	Men	Junior Men	Youth Boys	Women/Junior	Youth Girls
100m/110m	1.067m	0.990m	0.914m	0.840m	0.762m
400m	0.914m	0.914m	0.840m	0.762m	0.762m

Note: Due to manufacturing varieties, hurdles up to 1.000m are also acceptable in the Junior 110m Hurdles.

In each case there shall be a tolerance allowance of 3mm, above and below the standard heights, to allow for variation in the manufacture. The width of the hurdles shall be from 1.18m to 1.20m. The maximum length of the base shall be 70cm. The total weight of the hurdles shall be not less than 10kg.

4. The height of the top bar shall be 7cm. The thickness of this bar should be between 1cm and 2.5cm, and the top edges should be rounded. The bar should be firmly fixed at the extremities.
5. The top bar should be painted with white and black stripes, or with other strong distinctive contrasting colours (and also in contrast with the surrounding environment), such that the lighter stripes, which should be at least 22.5cm wide are on the outside.
6. All races shall be run in lanes and each athlete shall keep to his own lane throughout, except as provided in Rule 163.4.
7. Each athlete shall jump each hurdle. Failure to do so will result in a disqualification.

In addition, an athlete shall be disqualified, if he:

- (a) trails his foot or leg below the horizontal plane of the top of any hurdle at the instant of clearance,
 - (b) jumps any hurdle not in his own lane, or
 - (c) in the opinion of the Referee deliberately knocks down any hurdle.
8. Except as provided in Rule 168.7(c), the knocking down of hurdles shall not result in disqualification nor prevent a Record being made.
 9. For a World Record, all hurdles must comply with the specifications of this Rule.

RULE 169
Steeplechase Races

1. The standard distances shall be 2000m and 3000m.
2. There shall be 28 hurdle jumps and 7 water jumps included in the 3000m event, and 18 hurdle jumps and 5 water jumps in the 2000m event.
3. For the steeplechase events, there shall be five jumps in each lap after the finish line has been passed for the first time, with the water jump as the fourth. The jumps shall be evenly distributed, so that the distance between the jumps shall be approximately one fifth of the nominal length of the lap.
Note: In the 2000m event, if the water jump is on the inside of the track, the finish line has to be passed twice before the first lap with five jumps.
4. In the 3000m event, the distance from the start to the beginning of the first lap shall not include any jumps, the hurdles being removed until the athletes have entered the first lap. In the 2000m event, the first jump is at the third hurdle of a normal lap. The previous hurdles shall be removed until the athletes have passed them for the first time.
5. The hurdles shall be 0.914m high for men's events and 0.762m for women's events ($\pm 3\text{mm}$ both) and shall be at least 3.94m wide. The section of the top bar of the hurdles, and the hurdle at the water jump, shall be 12.7cm square.

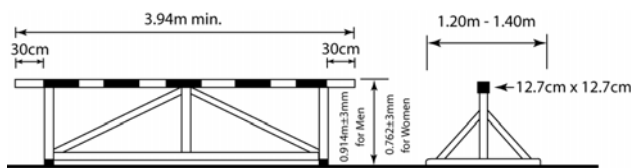

Figure 3 - Example of steeplechase hurdle

The hurdle at the water jump shall be $3.66\text{m} \pm 0.02\text{m}$ wide, and shall be firmly fixed to the ground, so that no horizontal movement is possible.

The top bars should be painted with white and black stripes, or with other strong distinctive contrasting colours (and also in contrast with the surrounding environment), such that the lighter

stripes, which should be at least 22.5cm wide, are on the outside. The weight of each hurdle shall be between 80kg and 100kg. Each hurdle shall have on either side a base between 1.2m and 1.4m (see Figure 3).

The hurdle shall be placed on the track so that 30cm of the top bar will extend inside the inner edge of the track.

Note: It is recommended that the first hurdle taken in the race should be at least 5m in width.

6. The water jump, including the hurdle, shall be $3.66\text{m} \pm 0.02\text{m}$ in length and the water pit shall be $3.66\text{m} \pm 0.02\text{m}$ in width.

The bottom of the water pit shall consist of a synthetic surface, or matting, of sufficient thickness to ensure safe landing, and allow for the spikes to grip satisfactorily. The depth of the water closest to the hurdle shall be 70cm for approximately 30cm. From there, the bottom shall have a uniform slope upwards to the level of the track at the farther end of the water pit. At the start of a race, the surface of the water shall be level with the surface of the track within a margin of 2cm.

Note: The depth of the water in the pit from the track surface level may be reduced from 70cm maximum down to 50cm minimum. The uniform slope of the bottom of the water shall be maintained as shown in Figure 4. It is recommended that all new water pits be constructed to the shallower depth.

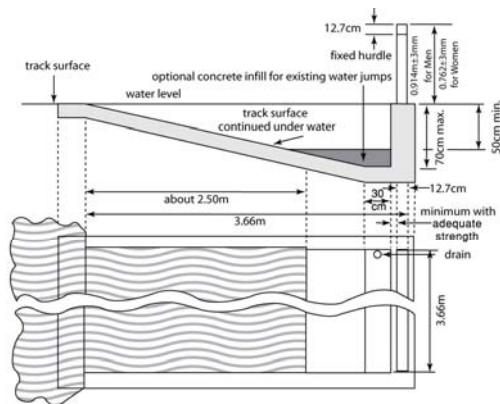

Figure 4 - Water jump

7. Each athlete shall go over or through the water and shall jump each hurdle. Failure to do so will result in a disqualification. In addition, an athlete shall be disqualified, if he
- steps to the one side or other of the water jump, or
 - trails his foot or leg below the horizontal plane of the top of any hurdle at the instant of clearance.
- Provided this Rule is observed, an athlete may go over each hurdle in any manner.

RULE 170

Relay Races

- Lines 5cm wide shall be drawn across the track to mark the distances of the legs and to denote the scratch line.
- Each take-over zone shall be 20m long of which the scratch line is the centre. The zones shall start and finish at the edges of the zone lines nearest the start line in the running direction.
- The scratch lines of the first take-over zones for the 4x400m (or the second zones for the 4x200m) are the same as the start lines for the 800m.
- The take-over zones for the second and last take-overs (4x400m) will be the 10m lines either side of the start/finish line.
- The arc across the track at the entry to the back straight showing the positions at which the second leg athletes (4x400m) and third leg athletes (4x200m) are permitted to leave their respective lanes, shall be the same as the arc for the 800m event, described in Rule 163.5.
- 4x100m and, where possible, 4x200m relay races, shall be run entirely in lanes.
In 4x200m (if this event is not run entirely in lanes) and 4x400m relay races, the first lap, as well as that part of the second lap up to the line after the first bend (breakline), will be run entirely in lanes.
Note: In the 4x200m and 4x400m relay races, where not more than 4 teams are competing, it is recommended that only the first bend of the first lap should be run in lanes.
- In relay races of 4x100m and 4x200m, members of a team other than the first athlete may commence running not more than 10m outside the take-over zone (see Rule 170.2). A distinctive mark shall be made in each lane to denote this extended limit.
- In the 4x400m relay race, at the first take-over, which is carried out with the athletes remaining in their lanes, the second athletes are not permitted to begin running outside their take-over zones, and

shall start within this zone. Similarly, the third and fourth athletes shall begin running from within their take-over zones.

The second athletes in each team shall run in lanes as far as the nearer edge of the breakline marked after the first bend where athletes may leave their respective lanes. The breakline shall be an arced line, 5cm wide, across the track. To assist athletes identify the breakline small cones or prisms, 5cmx5cm and no more than 15cm high, preferably of different colour from the breakline and the lane lines, shall be placed on the lane lines immediately before the intersection of the lane lines and the breakline.

||

9. The athletes in the third and fourth legs of the 4x400m relay race shall, under the direction of a designated official, place themselves in their waiting position in the same order (inside to out) as the order of their respective team members as they complete 200m of their legs. Once the incoming athletes have passed this point, the waiting athletes shall maintain their order, and shall not exchange positions at the beginning of the take-over zone. If an athlete does not follow this Rule, his team shall be disqualified.

Note: In the 4x200m relay race (if this event is not run entirely in lanes) the athletes in the fourth leg shall line up in the order of the start list (inside to out).

10. In any relay race, when lanes are not being used, including when applicable, in 4x200m and 4x400m, waiting athletes can take an inner position on the track as incoming team members approach, provided they do not jostle or obstruct another athlete so as to impede his progress. In 4x200m and 4x400m, waiting athletes shall maintain the order in accordance with Rule 170.9.
11. Check-Marks. When all or the first portion of a relay race is being run in lanes, an athlete may place one check-mark on the track within his own lane, by using adhesive tape, maximum 5cmx40cm, of a distinctive colour which cannot be confused with other permanent markings. No other check-mark may be used.
12. The baton shall be a smooth hollow tube, circular in section, made of wood, metal or any other rigid material in one piece, the length of which shall be 28 to 30cm. The circumference shall be 12 to 13cm and it shall not weigh less than 50g. It should be coloured so as to be easily visible during the race.
13. The baton shall be carried by hand throughout the race. Athletes are not permitted to wear gloves or to place substances on their hands in order to obtain a better grip of the baton. If dropped, it

shall be recovered by the athlete who dropped it. He may leave his lane to retrieve the baton provided that, by doing so, he does not lessen the distance to be covered. Provided this procedure is adopted and no other athlete is impeded, dropping the baton shall not result in disqualification.

14. In all Relay Races, the baton shall be passed within the take-over zone. The passing of the baton commences when it is first touched by the receiving athlete and is completed the moment it is in the hand of only the receiving athlete. In relation to the take-over zone, it is only the position of the baton which is decisive, and not the position of the bodies of the athletes. Passing of the baton outside the take-over zone shall result in disqualification.
15. Athletes, before receiving and/or after handing over the baton, should keep in their lanes or zones, in this last case until the course is clear to avoid obstruction to other athletes. Rules 163.3 and 163.4 shall not apply to these athletes. If an athlete wilfully impedes a member of another team by running out of position or lane at the finish of his leg, his team shall be disqualified.
16. Assistance by pushing or by any other method shall result in disqualification.
17. Any four athletes from among those entered for the competition, whether for that or any other event, may be used in the composition of the relay team for any round. However, once a relay team has started in a competition, only two additional athletes may be used as substitutes in the composition of the team. If a team does not follow this Rule, it shall be disqualified.
18. The composition of a team and the order of running for a relay shall be officially declared no later than one hour before the published first call time for the first heat of each round of the competition. Further alterations must be verified by a medical officer appointed by the Organising Committee and may be made only until the final call time for the particular heat in which the team is competing. If a team does not follow this Rule, it shall be disqualified.

SECTION IV - FIELD EVENTS

RULE 180

General Conditions

Warm-up at the competition Area

1. At the competition area and before the beginning of the event, each athlete may have practice trials. In the case of throwing events, the practice trials will be in draw order and always under the supervision of the Judges.
2. Once a competition has begun, athletes are not permitted to use, for practice purposes, as appropriate,
 - (a) the runway or take-off area;
 - (b) implements;
 - (c) the circles or the ground within the sector with or without implements.

Markers

3. (a) In all field events where a runway is used, markers shall be placed alongside it, except for High Jump where the markers can be placed on the runway. An athlete may use one or two markers (supplied or approved by the Organising Committee) to assist him in his run-up and take-off. If such markers are not supplied, he may use adhesive tape but not chalk or similar substance nor anything which leaves indelible marks.
- (b) For throws made from a circle, an athlete may use one marker only. This marker may be placed only on the ground in the area immediately behind or adjacent to the circle. It must be temporary, in position only for the duration of each athlete's own trial, and shall not impair the view of the judges. No personal markers (other than those under Rule 187.21) may be placed in or beside the landing area.

Competing Order

4. The athletes shall compete in an order drawn by lot. If there is a qualifying round, there shall be a fresh drawing of lot for the final (see also Rule 180.5).

Trials

5. In all Field Events, except for the High Jump and Pole Vault, where there are more than eight athletes, each athlete shall be allowed three trials and the eight athletes with the best valid performances shall be allowed three additional trials. Except for

the High Jump and Pole Vault, no athlete shall have more than one trial recorded in any one round of the competition.

In the event of a tie for the last qualifying place, it shall be resolved as described in Rule 180.20.

Where there are eight athletes or fewer, each athlete shall be allowed six trials. If more than one fail to achieve a valid trial during the first three rounds, such athletes shall compete in subsequent rounds before those with valid trials, in the same relative order according to the original draw.

In both cases:

- (a) the competing order for the fourth and fifth rounds shall be in the reverse ranking order recorded after the first three rounds. The competing order for the final round shall be in the reverse ranking order recorded after the fifth round.
- (b) when the competing order is to be changed and there is a tie for any position, those tying shall compete in the same relative order according to the original draw.

Note (i): In competitions under Rules 1.1(d) to (j), the competing order for the last three rounds may be in the reverse order of the ranking recorded after the first three trials.

Note (ii): For Vertical Jumps, see Rule 181.2

- 6. In all International Competitions, except the World Championships (Outdoor, Indoor, Junior, and Youth) and Olympic Games, the number of trials in the horizontal Field Events may be reduced. This shall be decided by the National or International body having the control over the competition.

Except in competitions held under Rules 1.1(a), (b), (c), the organisers may determine that Vertical Jump competitions be held in a different format to that provided under this Rule, including limiting the total number of heights or trials which an athlete may attempt.

Completion of trials

- 7. The judge shall not raise a white flag to indicate a valid trial until a trial is completed.

The completion of a valid trial shall be determined as follows:

- (a) in the case of vertical jumps, once the judge has determined that there is no failure according to Rules 182.2, 183.2 or 183.4;
- (b) in the case of horizontal jumps once the athlete leaves the landing area in accordance with Rule 185.1;
- (c) in the case of throwing events, once the athlete leaves the

|| circle or runway in accordance with Rule 187.17.

Qualifying Competition

8. A qualifying round shall be held in field events in which the number of athletes is too large to allow the competition to be conducted satisfactorily in a single round (final). When a qualifying round is held, all athletes shall compete in, and qualify through, that round. Performances accomplished in a qualifying round shall not be considered as part of the competition proper.
9. The athletes shall be divided into two or more groups. Unless there are facilities for the groups to compete at the same time and under the same conditions, each group should start its warm-up immediately after the previous group has finished.
10. It is recommended that, in competitions of more than three days, a rest day be provided between qualifying competitions and the finals in the vertical jumping events.
11. The conditions for qualifying, the qualifying standard and the number of athletes in the final, shall be decided by the Technical Delegate(s). If no Technical Delegate(s) have been appointed the conditions shall be decided by the Organising Committee. For competitions conducted under Rules 1.1(a), (b), (c) and (f), there should be at least 12 athletes in the final.
12. In a qualifying competition, apart from the High Jump and the Pole Vault, each athlete shall be allowed up to three trials. Once an athlete has achieved the qualifying standard, he shall not continue in the qualifying competition.
13. In the qualifying competition for the High Jump and the Pole Vault, the athletes, not eliminated after three consecutive failures, shall continue to compete according to Rule 181.2 until the end of the last trial at the height set as the qualifying standard, unless the number of athletes for the final has been reached as defined in Rule 180.11.
14. If no athletes, or fewer than the required number of athletes, achieve the pre-set qualifying standard, the group of finalists shall be expanded to that number by adding athletes according to their performances in the qualifying competition. Ties for the last qualifying place in the overall standings of the competition shall be resolved as described in Rule 180.20 or Rule 181.8 as appropriate.
15. When a qualifying competition for the High Jump and Pole Vault

is held in two simultaneous groups, it is recommended that the bar be raised to each height at the same time in each group. It is also recommended that the two groups be of approximately equal strength.

Obstruction

16. If, for any reason, an athlete is hampered in a trial, the Referee shall have the authority to award him a substitute trial.

Delay

17. An athlete in a field event who unreasonably delays making a trial, renders himself liable to have that trial disallowed and recorded as a failure. It is a matter for the Referee to decide, having regard to all the circumstances, what is an unreasonable delay.

The official responsible shall indicate to an athlete that all is ready for the trial to begin, and the period allowed for this trial shall commence from that moment. If an athlete subsequently decides not to attempt a trial, it shall be considered a failure once that period allowed for the trial has elapsed.

For the Pole Vault, the time shall begin when the crossbar has been adjusted according to the previous wishes of the athlete. No additional time will be allowed for further adjustment.

If the time allowed elapses after an athlete has started his trial, that trial should not be disallowed.

The following times should not normally be exceeded:

Individual Events

Number of athletes left in the competition

	High Jump	Pole Vault	Other
More than 3	1min	1min	1min
2 or 3	1.5min	2min	1min
1	3min	5min	-
Consecutive trials	2min	3min	2min

Combined Events

Number of athletes left in the competition

	High Jump	Pole Vault	Other
More than 3	1min	1min	1min
2 or 3	1.5min	2min	1min
1	2min*	3min*	-

Consecutive trials 2min 3min 2min

* When there is only one athlete left, the mentioned times will be followed in the first trial only if the previous trial was made by the same athlete.

Note (i): A clock which shows the remaining time allowed should be visible to an athlete. In addition, an official shall raise and keep raised, a yellow flag, or otherwise indicate, during the final 15 seconds of the time allowed.

Note (ii): In the High Jump and Pole Vault, any change in the time period allowed for a trial shall not be applied until the bar is raised to a new height, except that the time specified for consecutive trials shall be applied whenever any athlete has two or more consecutive trials.

Note (iii): For the first trial of any athlete upon entering the competition, the time allowed for such trial will be one minute.

Note (iv): When calculating the number of competitors remaining in the competition this should include those athletes who could be involved in a jump off for first place.

Absence during Competition

18. An athlete may, with the permission of, and accompanied by, an official, leave the immediate area of the event during the progress of the competition.

Change of Competition Area

19. The appropriate Referee shall have the authority to change the place of the competition if, in his opinion, the conditions justify it. Such a change should be made only after a round has been completed.

Note: Neither the wind strength nor its change of direction is sufficient condition to change the place of the competition.

Ties

20. Except for the High Jump and Pole Vault, the second best performance of the athletes tying shall resolve the tie. Then, if necessary, the third best, and so on.

If the tie remains and concerns first place, the athletes having achieved the same results will compete again in the same order in a new trial until the tie is resolved.

Note: For Vertical Jumps, see Rule 181.8.

Result

21. Each athlete shall be credited with the best of all his trials, including those achieved in resolving a tie for the first place.

A. VERTICAL JUMPS

RULE 181

General Conditions

1. Before the competition begins, the Chief Judge shall announce to the athletes the starting height and the subsequent heights to which the bar will be raised at the end of each round, until there is only one athlete remaining having won the competition, or there is a tie for first place.

Trials

2. An athlete may commence jumping/vaulting at any height previously announced by the Chief Judge and may jump/vault at his own discretion at any subsequent height. Three consecutive failures, regardless of the height at which any of such failures occur, disqualify from further jumping/vaulting except in the case of a tie for first place.

The effect of this Rule is that an athlete may forego his second or third trial at a particular height (after failing first or second time) and still jump/vault at a subsequent height.

If an athlete forgoes a trial at a certain height, he may not make any subsequent trial at that height, except in the case of a tie for first place.

3. Even after all the other athletes have failed, an athlete is entitled to continue jumping until he has forfeited his right to compete further.
4. Unless there is only one athlete remaining and he has won the competition:
 - (a) the bar should never be raised by less than 2cm in the High Jump and 5cm in the Pole Vault after each round; and
 - (b) the increment of the raising of the bar should never increase.

These Rules 181.4 (a) and (b) shall not apply once the athletes still competing agree to raise it to a World Record height directly. After an athlete has won the competition, the height or heights to which the bar is raised shall be decided by the athlete, in consultation with the relevant Judge or Referee.

Note: This does not apply for a Combined Events Competition.

In a Combined Events Competition held under Rules 1.1(a),

(b), (c) and (f), each increase shall be uniformly 3cm in the High Jump and 10cm in the Pole Vault throughout the competition.

Measurements

5. All measurements shall be made, in whole centimetres, perpendicularly from the ground to the lowest part of the upper side of the bar.
6. Any measurement of a new height shall be made before athletes attempt such height. In all cases of Records, the Judges shall check the measurement when the bar is placed at the Record height and they shall re-check the measurement before each subsequent Record attempt if the bar has been touched since last measured.

Crossbar

7. The crossbar shall be made of fibre-glass, or other suitable material but not metal, circular in cross-section except for the end pieces. The overall length of the crossbar shall be 4.00m \pm 2cm in the High Jump and 4.50m \pm 2cm in Pole Vault. The maximum weight of the crossbar shall be 2kg in the High Jump and 2.25kg in Pole Vault. The diameter of the circular part of the crossbar shall be 30mm \pm 1mm.
The crossbar shall consist of three parts - the circular bar and two end pieces, each 30-35mm wide and 15-20cm long for the purpose of resting on the supports of the uprights.
These end pieces shall be circular or semicircular with one clearly defined flat surface on which the bar rests on the crossbar supports. This flat surface may not be higher than the centre of the vertical cross section of the crossbar. The end pieces shall be hard and smooth. They shall not be covered with rubber or any other material which has the effect of increasing the friction between them and the supports.
The crossbar shall have no bias and, when in place, shall sag a maximum of 2cm in the High Jump and 3cm in Pole Vault.
Control of elasticity: Hang a 3kg weight in the middle of the crossbar when in position. It may sag a maximum of 7cm in the High Jump and 11cm in Pole Vault.

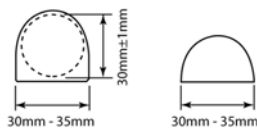

Figure 5 - Alternative ends for crossbar

Ties

8. Ties shall be resolved as follows:

- (a) The athlete with the lowest number of jumps at the height at which the tie occurs shall be awarded the higher place.
- (b) If the tie still remains, the athlete with the lowest total of failures throughout the competition up to and including the height last cleared, shall be awarded the higher place.
- (c) If the tie still remains:
 - (i) If it concerns the first place, the athletes tying shall have one jump at the next height, determined in accordance with Rule 181.1, after the height last cleared by the athletes tying, and if no decision is reached, the bar shall be raised if the tying athletes were successful, or lowered if not, 2cm for the High Jump and 5cm for the Pole Vault. They shall then attempt one jump at each height until the tie is resolved. Athletes so tying must jump on each occasion when resolving the tie (See example).
 - (ii) If it concerns any other place, the athletes shall be awarded the same place in the competition.

Note: This Rule (c) will not apply to Combined Events.

High Jump - Example

Heights announced by the Chief Judge at the beginning of competition: 1.75m; 1.80m; 1.84m; 1.88m; 1.91m; 1.94m; 1.97m; 1.99m...

Athlete	Heights							Failures	Jump Off			Pos
	1.75m	1.80m	1.84m	1.88m	1.91m	1.94m	1.97m		1.91m	1.89m	1.91m	
A	O	XO	O	XO	X-	XX	2	X	O	X	2	
B	-	XO	-	XO	-	-	XXX	2	X	O	O	1
C	-	O	XO	XO	-	XXX	2	X	X		3	
D	-	XO	XO	XO	XXX		3				4	

O = Cleared X = Failed – = Did not Jump

A, B, C and D all cleared 1.88m.

The Rule regarding ties now comes into operation; the Judges add up the total number of failures, up to and including the height last cleared, i.e. 1.88m.

"D" has more failures than "A", "B" or "C", and is therefore awarded fourth place. "A", "B" and "C" still tie and as this concerns the first place, they shall have one more jump at 1.91m which is the next height after the height last cleared by the athletes tying.

As all the athletes tying failed, the bar is lowered to 1.89m for another jump-off. As only "C" failed to clear 1.89m, the two other tying athletes, "A" and "B" shall have a third jump-off at 1.91m which only "B" cleared and is therefore declared the winner.

Extraneous forces

9. When it is clear that the bar has been displaced by a force not associated with an athlete (e.g. a gust of wind)
 - (a) if such displacement occurs after an athlete has cleared the bar without touching it, then the trial shall be considered successful, or
 - (b) if such displacement occurs under any other circumstance, a new trial shall be awarded.

RULE 182
High Jump

The Competition

1. An athlete shall take off from one foot.
2. An athlete fails if:
 - (a) After the jump, the bar does not remain on the supports because of the action of the athlete whilst jumping; or
 - (b) He touches the ground including the landing area beyond the vertical plane through the nearer edge of the crossbar, either between or outside the uprights with any part of his body, without first clearing the bar. However, if when he jumps, an athlete touches the landing area with his foot and in the opinion of the Judge, no advantage is gained, the jump for that reason should not be considered a failure.

Note: To assist in the implementation of this Rule a white line 50mm wide shall be drawn (usually by adhesive tape or similar material) between points 3m outside of each upright, the nearer edge of the line being drawn along the vertical plane through the

nearer edge of the crossbar.

The Runway and Take-off Area

3. The minimum length of the runway shall be 15m except in competitions held under Rules 1.1(a), (b), (c) and (f), where the minimum shall be 20m.

Where conditions permit, the minimum length should be 25m.

4. The maximum overall inclination in the last 15m of the runway and take-off area shall not exceed 1:250 along any radius of the semicircular area centred midway between the uprights and having the minimum radius specified in Rule 182.3. The landing area should be placed so the athlete's approach is up the inclination.
5. The take-off area shall be level or any inclination shall be in accordance with the requirements of Rule 182.4 and the IAAF Track and Field Facilities Manual.

Apparatus

6. Uprights. Any style of uprights or posts may be used, provided they are rigid.

They shall have supports for the crossbar firmly fixed to them.

They shall be sufficiently tall as to exceed the actual height to which the crossbar is raised by at least 10cm.

The distance between the uprights shall be not less than 4.00m nor more than 4.04m.

7. The uprights or posts shall not be moved during the competition unless the Referee considers that either the take-off or landing area has become unsuitable.

In such a case the change shall be made only after a round has been completed.

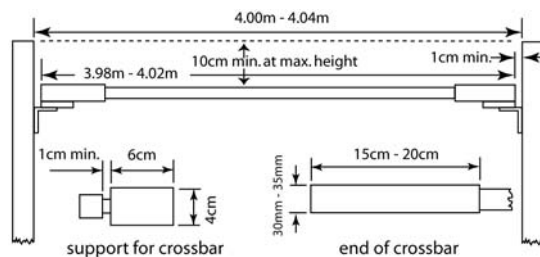

Figure 6 - High Jump uprights and crossbar

8. Crossbar supports. The supports shall be flat and rectangular, 4cm wide and 6cm long. They shall be firmly fixed to the uprights and immovable during the jump and shall each face the opposite upright. The ends of the crossbar shall rest on them in such a manner that, if the crossbar is touched by an athlete, it will easily fall to the ground, either forwards or backwards. The supports shall not be covered with rubber or with any other material which has the effect of increasing the friction between them and the surface of the crossbar, nor may they have any kind of springs. The supports shall be the same height above the take-off area immediately below each end of the crossbar.
9. There shall be a space of at least 1cm between the ends of the crossbar and the uprights.

The Landing Area

10. The landing area should measure not less than 5m long x 3m wide. It is recommended that the landing area be not smaller than 6m long x 4m wide x 0.7m high.
Note: The uprights and landing area should also be designed so that there is a clearance of at least 10cm between them when in use, to avoid displacement of the crossbar through a movement of the landing area causing contact with the uprights.

RULE 183
Pole Vault

The Competition

1. Athletes may have the crossbar moved only in the direction of the landing area so that the edge of the crossbar nearest the athlete can be positioned at any point from that directly above the back end of the box to a point 80cm in the direction of the landing area. An athlete shall, before the competition starts, inform the appropriate official of the position of the crossbar he requires for his first trial and this position shall be recorded. If subsequently an athlete wants to make any changes, he should immediately inform the appropriate official before the crossbar has been set in accordance with his initial wishes. Failure to do this shall lead to the start of his time limit.
Note: A line, 1cm wide and of distinguishable colour, shall be drawn at right angles to the axis of the runway, in line with the back end of the box. A similar line shall appear on the surface of the landing area and be prolonged as far as the outside edge of the uprights.

2. An athlete fails if:
- after the vault, the bar does not remain on the pegs because of the action of an athlete whilst vaulting; or
 - he touches the ground, including the landing area beyond the vertical plane through the back end of the box with any part of his body or with the pole, without first clearing the bar; or
 - after leaving the ground he places his lower hand above the upper one or moves the upper hand higher on the pole.
 - during the vault an athlete steadies or replaces the bar with his hand(s).

Note (i): It is not a failure if an athlete runs outside the white lines marking the runway at any point.

Note (ii) It is not a failure if the pole touches the landing mats, in the course of a trial, after properly being planted in the box.

3. Athletes may, during the competition, place a substance on their hands or on the pole, in order to obtain a better grip.
Athletes shall not use tape on the hands or fingers except in the case of the need to cover an open wound.
4. After the release of the pole, no one including the athlete shall be allowed to touch the pole unless it is falling away from the bar or uprights. If it is touched, however, and the Referee is of the opinion that, but for the intervention, the bar would have been knocked off, the vault shall be recorded as a failure.
5. If, in making a trial, an athlete's pole is broken, it shall not be counted as a failure and the vaulter shall be awarded a new trial.

The Runway

6. The minimum length of the runway shall be 40m and where conditions permit, 45m. It shall have a width of $1.22\text{m} \pm 0.01\text{m}$ and shall be marked by white lines 5cm in width.
Note: For all tracks constructed before 1 January 2004 the runway may have a width of maximum 1.25m.
7. The maximum lateral inclination of the runway shall be 1:100 and in the last 40m of the runway the overall downward inclination in the direction of running shall not exceed 1:1000.

Apparatus

8. Box. The take-off for the Pole Vault shall be from a box. It shall be constructed of suitable material, preferably with rounded upper edges and shall be sunk level with the runway. It shall be 1m in length, measured along the inside of the bottom of the box, 60cm in width at the front end and tapering to 15cm in width at the bottom of the stop board. The length of the box at runway

level and the depth of the stop board are determined by the angle of 105° formed between the base and the stop board.

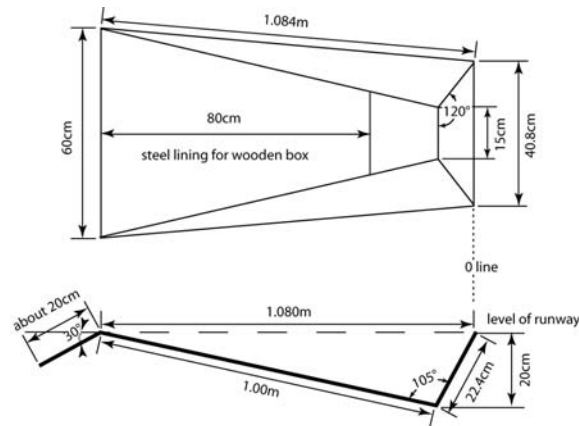

Figure 7 - Pole vault box (top and side view)

The base of the box shall slope from runway level at the front end to a vertical distance below ground level of 20cm at the point where it meets the stop board. The box should be constructed in such a manner that the sides slope outwards and end next to the stop board at an angle of approximately 120° to the base.

If the box is constructed of wood, the bottom shall be lined with 2.5mm sheet metal for a distance of 80cm from the front of the box.

9. Uprights. Any style of uprights or posts may be used, provided they are rigid. The metallic structure of the base and the lower part of the uprights must be covered with padding of appropriate material in order to provide protection to the athletes and the poles.
10. Crossbar support. The crossbar shall rest on pegs so that if it is touched by an athlete or his pole, it will fall easily to the ground in the direction of the landing area. The pegs shall be without notches or indentations of any kind, of uniform thickness throughout and not more than 13mm in diameter. They shall not extend more than 55mm from the supporting members, which should be smooth and extend 35-40mm above the pegs.

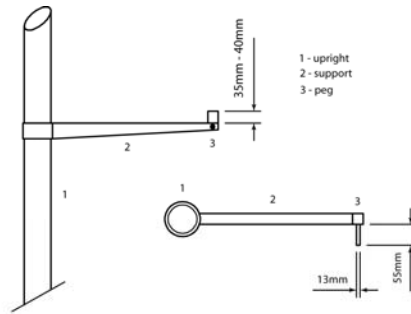

Figure 8 - Crossbar support (view from landing area and top view)

The distance between the pegs shall be 4.30-4.37m. The pegs shall not be covered with rubber or with any other material which has the effect of increasing the friction between them and the surface of the bar, nor may they have any kind of springs.

Note: To lessen the chance of injury to an athlete by his falling on the feet of the uprights, the pegs supporting the crossbar may be placed upon extension arms permanently attached to the uprights, thus allowing the uprights to be placed wider apart, without increasing the length of the crossbar (see Figure 8).

Vaulting Poles

11. Athletes may use their own poles. No athlete shall use any other athlete's pole except with the consent of the owner.

The pole may be of any material or combination of materials and of any length or diameter, but the basic surface must be smooth.

The pole may have protective layers of tape at the grip and at the bottom end.

The Landing Area

12. The landing area should measure not less than 5m long (excluding the front pieces) x 5m wide. The sides of the landing area nearest to the box shall be placed 10cm to 15cm from the box and shall slope away from the box at an angle of approximately 45° (see Figure 9).

For competitions under Rules 1.1(a), (b), (c), (e)(i) and (f),

the landing area shall be not smaller than 6m long (excluding the front pieces) x 6m wide x 0.8m high. The front pieces must be at least 2m long.

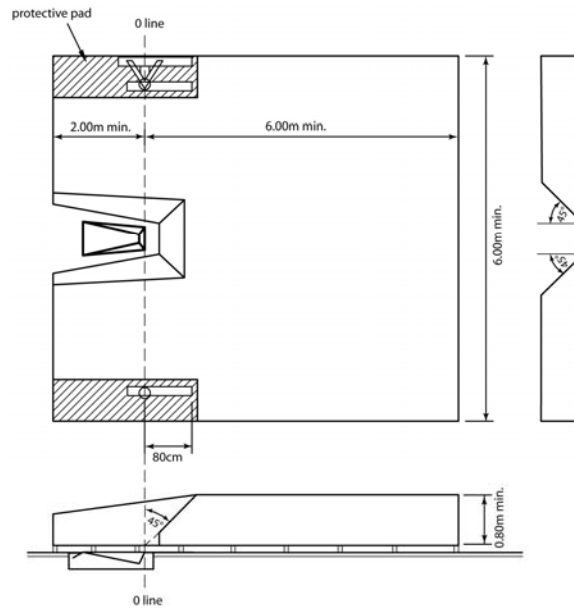

Figure 9 - Pole Vault landing area (top and side views)

B. HORIZONTAL JUMPS

RULE 184

General Conditions

Measurements

1. In all horizontal jumping events, distances shall be recorded to the nearest 0.01m below the distance measured if the distance measured is not a whole centimetre.

Runway

2. The minimum length of the runway shall be 40m, measured from the relevant take-off line to the end of the runway. It shall have a width of $1.22\text{m} \pm 0.01\text{m}$ and shall be marked by white lines 5cm in width.

Note: For all tracks constructed before 1 January 2004 the runway may have a width of maximum 1.25m.

3. The maximum lateral inclination of the runway shall be 1:100 and in the last 40m of the runway the overall downward inclination in the direction of running shall not exceed 1:1000.

Wind Measurement

4. The wind speed shall be measured for a period of 5 seconds from the time an athlete passes a mark placed alongside the runway, for the Long Jump 40m from the take-off line and for the Triple Jump 35m. If an athlete runs less than 40m or 35m, as appropriate, the wind velocity shall be measured from the time he commences his run.
5. The wind gauge shall be placed 20m from the take-off board. It shall be positioned 1.22m high and not more than 2m away from the runway.
6. The wind gauge shall be the same as described in Rule 163.11. It shall be operated and read as described in Rules 163.12 and 163.10 respectively.

RULE 185

Long Jump

The Competition

1. An athlete fails if:
 - (a) he while taking off, touches the ground beyond the take-off line with any part of his body, whether running up without jumping or in the act of jumping; or

- (b) he takes off from outside either end of the board, whether beyond or before the extension of the take-off line; or
- (c) he touches the ground between the take-off line and the landing area; or
- (d) he employs any form of somersaulting whilst running up or in the act of jumping; or
- (e) in the course of landing he touches the ground outside the landing area closer to the take-off line than the nearest break made in the sand; or
- (f) when leaving the landing area, his first contact with the ground outside the landing area is closer to the take-off line than the nearest break made in the sand on landing, including any break made on overbalancing on landing which is completely inside the landing area but closer to the take-off line than the initial break made on landing.

Note (i): It is not a failure if an athlete runs outside the white lines marking the runway at any point.

Note (ii): It is not a failure under Rule 185.1(b) if a part of an athlete's shoe/foot is touching the ground outside either end of the take-off board, before the take-off line.

Note (iii): It is not a failure if in the course of landing, an athlete touches, with any part of his body, the ground outside the landing area, unless such contact is the first contact or contravenes Rule 185.1(e).

Note (iv): It is not a failure if an athlete walks back through the landing area after having left the landing area in a correct way.

Note (v): Except as described in Rule 185.1(b), if an athlete takes off before reaching the board it shall not, for that reason, be counted as a failure.

- 2. When leaving the landing area, an athlete's first contact by foot with its border or the ground outside shall be further from the take-off line than the nearest break in the sand (see Rule 185.1(f)).

Note: This first contact is considered leaving.

- 3. All jumps shall be measured from the nearest break in the landing area made by any part of the body to the take-off line, or take-off line extended (see Rule 185.1(f)). The measurement shall be taken perpendicular to the take-off line or its extension.

The Take-off Board

- 4. The take-off shall be marked by a board sunk level with the runway and the surface of the landing area. The edge of the board

which is nearer to the landing area shall be the take-off line. Immediately beyond the take-off line there shall be placed a plasticine indicator board for the assistance of the Judges.

5. The distance between the take-off line and the far end of the landing area shall be at least 10m.
6. The take-off line shall be placed between 1m and 3m from the nearer end of the landing area.
7. Construction. The take-off board shall be rectangular, made of wood or other suitable rigid material and shall measure $1.22\text{m} \pm 0.01\text{m}$ long, $20\text{cm} (\pm 2\text{mm})$ wide and 10cm deep. It shall be white.
8. Plasticine Indicator Board. This shall consist of a rigid board, $10\text{cm} (\pm 2\text{mm})$ wide and $1.22\text{m} \pm 0.01\text{m}$ long made of wood or any other suitable material and shall be painted in a contrasting colour to the take-off board. Where possible, the plasticine should be of a third contrasting colour. The board shall be mounted in a recess or shelf in the runway, on the side of the take-off board nearer the landing area. The surface shall rise from the level of the take-off board to a height of $7\text{mm} (\pm 1\text{mm})$. The edges shall either slant at an angle of 45° with the edge nearer to the runway covered with a plasticine layer along its length 1mm thick or shall be cut away such that the recess, when filled with plasticine shall slant at an angle of 45° (see Figure 10).

The upper part of the indicator board shall also be covered for the first 10mm approximately and along its entire length, by a plasticine layer.

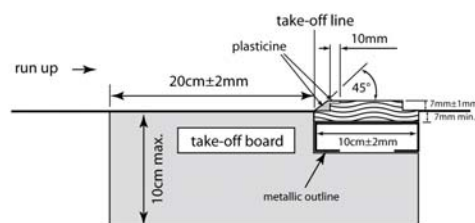

Figure 10 - Take-off board and plasticine indicator board

When mounted in this recess, the whole assembly shall be sufficiently rigid to accept the full force of the athlete's foot.

The surface of the board beneath the plasticine shall be of a material in which the spikes of an athlete's shoe will grip and not skid.

The layer of plasticine can be smoothed off by means of a roller or suitably shaped scraper for the purposes of removing the footprint of an athlete.

Note: It will be found very helpful to have spare plasticine boards available so that, while a footprint is being eliminated, the competition is not delayed.

The Landing Area

9. The landing area shall have a minimum width of 2.75m and a maximum width of 3m. It shall, if possible, be so placed that the middle of the runway, if extended, would coincide with the middle of the landing area.

Note: When the axis of the runway is not in line with the centre line of the landing area, a tape, or if necessary, two tapes, should be placed along the landing area so that the above is achieved (see Figure 11).

10. The landing area should be filled with soft damp sand, the top surface of which shall be level with the take-off board.

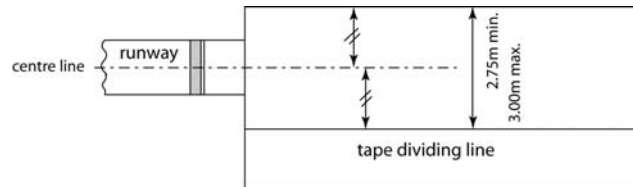

Figure 11 - Centralised Long Jump / Triple Jump landing area

RULE 186
Triple Jump

The Rules for the Long Jump apply to the Triple Jump with the following additions:

The Competition

1. The Triple Jump shall consist of a hop, a step and a jump in that order.
2. The hop shall be made so that an athlete lands first on the same foot as that from which he has taken off; in the step he shall land on the other foot, from which, subsequently, the jump is

performed.

It shall not be considered a failure if an athlete, while jumping, touches the ground with the "sleeping" leg.

Note: Rule 185.1(c) does not apply to the normal landings from the hop and step phases.

The Take-off Board

3. The distance between the take-off line for men and the far end of the landing area shall be at least 21m.
4. For International Competitions, it is recommended that the take-off line shall be not less than 13m for men and 11m for women from the nearer end of the landing area. For any other competition, this distance shall be appropriate for the level of competition.
5. Between the take-off board and the landing area there shall, for the step and jump phases, be a take-off area of $1.22\text{m} \pm 0.01\text{m}$ wide providing firm and uniform footing.

Note: For all tracks constructed before 1 January 2004, this take-off area may have a width of maximum 1.25m.

C. Throwing Events

RULE 187

General Conditions***Official Implements***

1. In all International Competitions, the implements used shall comply with IAAF specifications. Only implements which hold a current valid IAAF certificate of approval may be used. The following table shows the implement to be used by each age group:

Implement	Girls/Women	Boys	Men	Men
	Youth/Junior/Senior	Youth	Junior	Senior
Shot	4.000kg	5.000kg	6.000kg	7.260kg
Discus	1.000kg	1.500kg	1.750kg	2.000kg
Hammer	4.000kg	5.000kg	6.000kg	7.260kg
Javelin	600g	700g	800g	800g

Note: A standard form of Implement Certification Application is available, on request, from the IAAF Office, or may be downloaded from the IAAF website.

2. Except as provided below, all such implements shall be provided by the Organising Committee. The Technical Delegate(s) may, based on the relevant Technical Regulations of each competition, allow athletes to use their own implements or those provided by a supplier, provided that such implements are IAAF certified, checked and marked as approved by the Organising Committee before the competition and made available to all athletes. Such implements will not be accepted if the same model is already on the list of those provided by the Organising Committee.
3. No modification shall be made to any implements during the competition.

Personal Safeguards

4. (a) An athlete shall not use any device of any kind - e.g. the taping of two or more fingers together or using weights attached to the body - which in any way provides assistance when making a trial. An athlete shall not use tape on the hand except when tape is needed to cover an open cut or wound. However an athlete in the Hammer Throw may tape individual fingers. The taping should be shown to the Chief Judge before the event starts.
- (b) An athlete shall not use gloves except in the Hammer Throw.

In this case, the gloves shall be smooth on the back and on the front and the tips of the glove fingers, other than the thumb, shall be open.

- (c) In order to obtain a better grip, an athlete may use a suitable substance on his hands only. In addition, hammer throwers may use such substances on their gloves, and shot putters may use such substances on their neck.
- (d) In order to protect the spine from injury, an athlete may wear a belt of leather or other suitable material.
- (e) In the Shot Put an athlete may wear a bandage at the wrist in order to protect it from injury.
- (f) In the Javelin Throw, an athlete may wear an elbow protection.
- (g) An athlete may wear other protection e.g. knee support, provided the athlete has IAAF approval on medical advice for its use in competition.

Throwing Circle

5. The rim of the circles shall be made of band iron, steel or other suitable material, the top of which shall be flush with the ground outside. The ground surrounding the circle may be concrete, synthetic, asphalt, wood or any other suitable material.
The interior of the circle may be constructed of concrete, asphalt or some other firm but not slippery material. The surface of this interior shall be level and $2\text{cm}\pm 6\text{mm}$ lower than the upper edge of the rim of the circle.
In the Shot Put, a portable circle meeting these specifications is permissible.
6. The inside diameter of the circle shall be $2.135\text{m}\pm 5\text{mm}$ in the Shot Put and the Hammer Throw and $2.50\text{m}\pm 5\text{mm}$ in the Discus Throw.
The rim of the circle shall be at least 6mm thick and shall be white.
The hammer may be thrown from the discus circle provided the diameter of this circle is reduced from 2.50m to 2.135m by placing a circular ring inside.

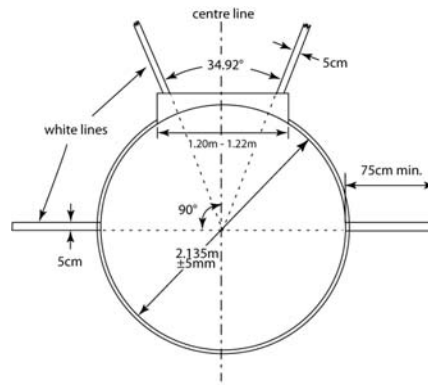

Figure 12 - Layout of Shot Put circle

7. A white line 5cm wide shall be drawn from the top of the rim extending for at least 75cm on either side of the circle. The white line may be painted or made of wood or other suitable material. The rear edge of the white line shall form a prolongation of a theoretical line through the centre of the circle at right angles to the centre line of the landing sector.

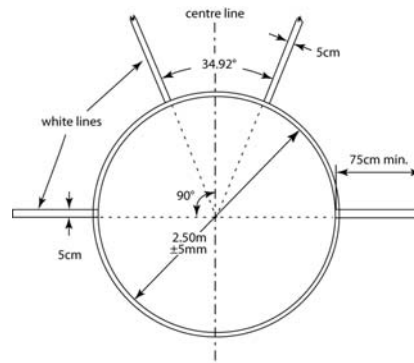

Figure 13 - Layout of Discus Throw circle

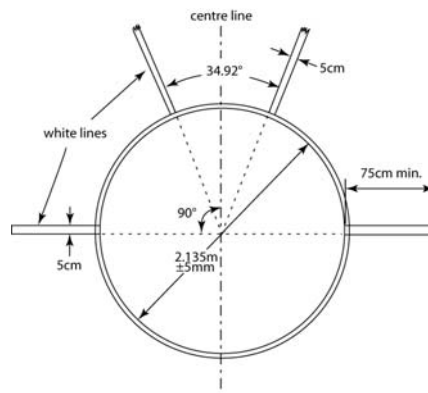

Figure 14 - Layout of Hammer Throw circle

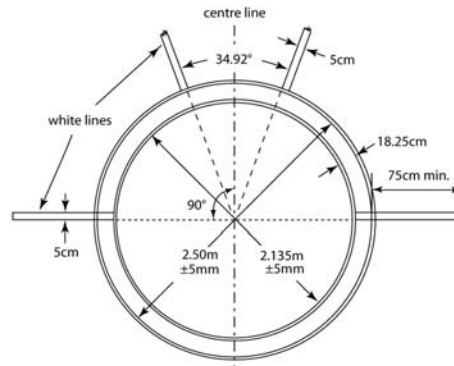

Figure 15 - Layout of concentric circles for Discus and Hammer Throw circle

8. An athlete may not spray nor spread any substance in the circle or on his shoes nor roughen the surface of the circle.

Javelin Throw Runway

9. In the Javelin Throw the minimum length of the runway shall be 30m. Where conditions permit, the minimum length shall be 33.5m. It shall be marked by two parallel white lines 5cm wide

and 4m apart. The throw shall be made from behind an arc of a circle drawn with a radius of 8m. The arc shall consist of a strip painted or made of wood 7cm wide. It shall be white and be flush with the ground. Lines shall be drawn from the extremities of the arc at right angles to the parallel lines marking the runway. These lines shall be white, 75cm long and 7cm wide. The maximum lateral inclination of the runway shall be 1:100 and in the last 20m of the runway the overall downward inclination in the direction of running shall not exceed 1:1000.

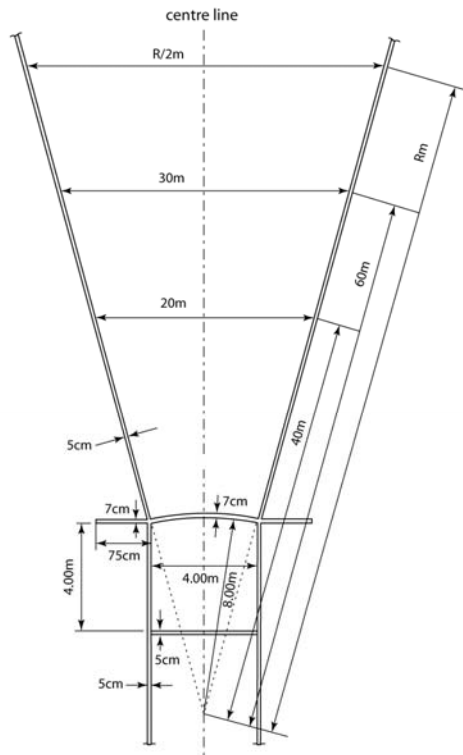

Figure 16 - Javelin Throw runway and landing sector (not to scale)

Landing sector

10. The landing sector shall consist of cinders or grass or other suitable material on which the implement makes an imprint.
11. The maximum overall downward inclination of the landing sector, in the throwing direction, shall not exceed 1:1000.
12. (a) Except for the Javelin Throw, the landing sector shall be marked with white lines 5cm wide at an angle of 34.92° such that the inner edge of lines, if extended, would pass through the centre of the circle.
Note: The 34.92° sector may be laid out accurately by making the distance between the two points on the sector lines 20m from the centre of the circle 12m (20x0.60m) apart. Thus for every 1m from the centre of the circle, the distance across shall be increased by 60cm
- (b) In the Javelin Throw, the landing sector shall be marked with white lines 5cm wide such that the inner edge of the lines, if extended, would pass through the two intersections of the inner edges of the arc, and the parallel lines marking the runway and intersect at the centre of the circle of which the arc is part (see Figure 16). The sector is thus about 29°.

Trials

13. In the Shot Put, Discus Throw and Hammer Throw, implements shall be thrown from a circle, and in the Javelin Throw from a runway. In the case of trials made from a circle, an athlete shall commence his trial from a stationary position inside the circle. An athlete is allowed to touch the inside of the rim. In the Shot Put he is also allowed to touch the inside of the stop board described in Rule 188.2.
14. It shall be a failure if an athlete in the course of a trial:
 - (a) improperly releases the shot or the javelin,
 - (b) after he has stepped into the circle and begun to make a throw, touches with any part of his body the top of the rim or the ground outside the circle,
 - (c) in the Shot Put, touches with any part of his body the top of the stop board,
 - (d) in the Javelin Throw, touches with any part of his body the lines which mark the runway or the ground outside.*Note: It will not be considered a failure if the discus or any part of the hammer strikes the cage after release provided that no other Rule is infringed.*
15. Provided that, in the course of a trial, the Rules relative to each

throwing event have not been infringed, an athlete may interrupt a trial once started, may lay the implement down inside or outside the circle or runway and may leave it.

When leaving the circle or runway he shall step out as required in paragraph 17 before returning to the circle or runway to begin a fresh trial.

Note: All the moves permitted by this paragraph shall be included in the maximum time for a trial given in Rule 180.17.

16. It shall be a failure if the shot, the discus, the hammer head or the tip of the javelin in contacting the ground when it first lands touches the sector line or the ground outside the sector line.

17. An athlete shall not leave the circle or runway until the implement has touched the ground.

(a) For throws made from a circle, when leaving the circle, an athlete's first contact with the top of the rim or the ground outside the circle shall be completely behind the white line which is drawn outside the circle running, theoretically, through the centre of the circle.

Note: The first contact with the top of the rim or the ground outside the circle is considered leaving.

(b) In the case of the Javelin Throw, when an athlete leaves the runway, the first contact with the parallel lines or the ground outside the runway shall be completely behind the white line of the arc at right angles to the parallel lines. Once the implement has touched the ground, an athlete will also be considered to have left the runway, upon making contact with or behind a line (painted, or theoretical and indicated by markers beside the runway) drawn across the runway, four metres back from the end points of the throwing arc. Should an athlete be behind that line and inside the runway at the moment the implement touches the ground, he shall also be considered to have left the runway.

18. After each throw, implements shall be carried back to the area next to the circle or runway and never thrown back.

Measurements

19. In all throwing events, distances shall be recorded to the nearest 0.01m below the distance measured if the distance measured is not a whole centimetre.

20. The measurement of each throw shall be made immediately after the trial:

(a) from the nearest mark made by the fall of the shot, discus

- and hammer head, to the inside of the circumference of the circle along a line to the centre of the circle;
- (b) in Javelin Throw, from where the tip of the javelin first struck the ground to the inside edge of the arc, along a line to the centre of the circle of which the arc is part.

Markers

21. A distinctive flag or marker may be provided to mark the best throw of each athlete, in which case it shall be placed along, and outside, the sector lines.
- A distinctive flag or marker may also be provided to mark the existing World Record and, when appropriate, the existing Area, National or Meeting Record.

RULE 188

Shot Put

The Competition

1. The shot shall be put from the shoulder with one hand only. At the time an athlete takes a stance in the circle to commence a put, the shot shall touch or be in close proximity to the neck or the chin and the hand shall not be dropped below this position during the action of putting. The shot shall not be taken behind the line of the shoulders.

Note: Cartwheeling techniques are not permitted.

The Stop Board

2. Construction. The board shall be white and made of wood or other suitable material in the shape of an arc so that the inner edge coincides with the inner edge of the rim of the circle. It shall be placed mid-way between the sector lines, and be so made that it can be firmly fixed to the ground.

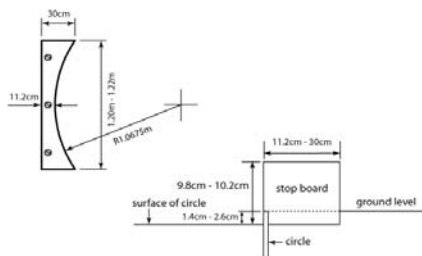

Figure 17 - Shot Put stop board (top and side view)

Note: Stop boards to the 1983/84 IAAF specifications remain acceptable.

- Measurements. The board shall measure 11.2cm to 30cm wide, with a chord of 1.21m \pm 0.01m for an arc of the same radius as the circle and 10cm \pm 0.2cm high in relation to the level of the inside of the circle.

The Shot

- Construction. The shot shall be of solid iron, brass or any metal not softer than brass, or a shell of such metal filled with lead or other material. It shall be spherical in shape and its surface shall have no roughness and the finish shall be smooth. To be smooth, the surface average height must be less than 1.6 μ m, i.e. a roughness number N7 or less.
- It shall conform to the following specifications:

Shot

Minimum weight for admission to competition and acceptance of a Record:

4.000kg	5.000kg	6.000kg	7.260kg
---------	---------	---------	---------

Information for manufacturers:

Range for supply of implement for competition	4.005kg 4.025kg	5.005kg 5.025kg	6.005kg 6.025kg	7.265kg 7.285kg
---	--------------------	--------------------	--------------------	--------------------

Minimum Diameter	95mm	100mm	105mm	110mm
Maximum Diameter	110mm	120mm	125mm	130mm

RULE 189
Discus Throw

The Discus

1. Construction. The body of the discus may be solid or hollow and shall be made of wood, or other suitable material, with a metal rim, the edge of which shall be circular. The cross section of the edge shall be rounded in a true circle having a radius of approximately 6mm. There may be circular plates set flush into the centre of the sides. Alternatively, the discus may be made without metal plates, provided that the equivalent area is flat and the measurements and total weight of the implement correspond to the specifications.

Each side of the discus shall be identical and shall be made without indentations, projections or sharp edges. The sides shall taper in a straight line from the beginning of the curve of the rim to a circle of a radius of 25mm to 28.5mm from the centre of the discus.

The profile of the discus shall be designed as follows. From the beginning of the curve of the rim the thickness of the discus increases regularly up to the maximum thickness D. This maximum value is achieved at a distance of 25 mm to 28.5mm from the axis of the discus Y. From this point up to the axis Y the thickness of the discus is constant. Upper and lower side of the discus must be identical, also the discus has to be symmetrical concerning rotation around the axis Y.

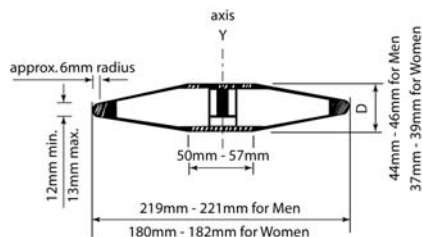

Figure 18 – Discus

The discus, including the surface of the rim shall have no roughness and the finish shall be smooth (see Rule 188.4) and uniform throughout.

2. It shall conform to the following specifications:

Discus

Minimum weight for admission to competition and acceptance of a Record :				
	1.000kg	1.500kg	1.750kg	2.000kg
Information for manufacturers: Range for supply of implement for competition				
	1.005kg	1.505kg	1.755kg	2.005kg
	1.025kg	1.525kg	1.775kg	2.025kg
Outside diameter of metal rim				
Min.	180mm	200mm	210mm	219mm
Max.	182mm	202mm	212mm	221mm
Diameter of metal plate or flat centre area				
Min.	50mm	50mm	50mm	50mm
Max.	57mm	57mm	57mm	57mm
Thickness of metal plate or flat centre area				
Min.	37mm	38mm	41mm	44mm
Max.	39mm	40mm	43mm	46mm
Thickness of metal rim (6mm from edge)				
Min.	12mm	12mm	12mm	12mm
Max.	13mm	13mm	13mm	13mm

RULE 190
Discus Cage

- All discus throws shall be made from an enclosure or cage to ensure the safety of spectators, officials and athletes. The cage specified in this Rule is intended for use when the event takes place in the arena with other events taking place at the same time or when the event takes place outside the arena with spectators present. Where this does not apply, and especially in training areas, a much simpler construction may be satisfactory. Advice is available, on request, from national organisations or from the IAAF Office.
Note: The hammer cage specified in Rule 192 may also be used for Discus Throw, either by installing 2.135/2.50m concentric circles, or by using the extension of the gates of that cage with a separate discus circle installed in front of the hammer circle.
- The cage should be designed, manufactured and maintained so as to be capable of stopping a 2kg discus moving at a speed of up to 25 metres per second. The arrangement should be such that there is no danger of ricocheting or rebounding back towards the athlete or over the top of the cage. Provided that it satisfies all the

requirements of this Rule, any form of cage design and construction can be used.

3. The cage should be U-shaped in plan as shown in Figure 19. The width of the mouth should be 6m, positioned 7m in front of the centre of the throwing circle. The end points of the 6m wide mouth shall be the inner edge of the cage netting. The height of the netting panels or draped netting at their lowest point should be at least 4m.

Provision should be made in the design and construction of the cage to prevent a discus forcing its way through any joints in the cage or the netting or underneath the netting panels or draped netting.

Note (i): The arrangement of the rear panels/netting is not important provided the netting is a minimum of 3.00m away from the centre of the circle.

Note (ii): Innovative designs that provide the same degree of protection and do not increase the danger zone compared with conventional designs may be IAAF certified.

Note (iii) The cage side particularly alongside the track may be lengthened and/or increased in height so as to provide greater protection to athletes competing on the adjoining track during a discus competition.

4. The netting for the cage can be made from suitable natural or synthetic fibre cord or, alternatively, from mild or high tensile steel wire. The maximum mesh size shall be 44mm for cord netting and 50mm for steel wire.

Note: Further specifications for the netting and safety inspection procedures are set out in the IAAF Track and Field Facilities Manual.

5. The maximum danger sector for discus throws from this cage is approximately 69°, when used by both right and left handed throwers in the same competition. The position and alignment of the cage in the arena is, therefore, critical for its safe use.

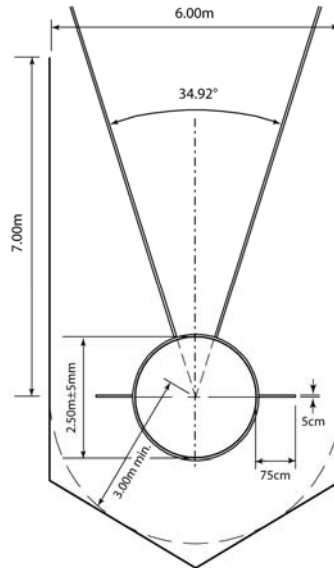

Figure 19 - Cage for Discus Throw only

RULE 191 Hammer Throw

The Competition

1. An athlete, in his starting position prior to the preliminary swings or turns, is allowed to put the head of the hammer on the ground inside or outside the circle.
2. It shall not be considered a failure if the head of the hammer touches the ground inside or outside the circle, or the top of the rim. The athlete may stop and begin the throw again, provided no other Rule has been breached.
3. If the hammer breaks during a throw or while in the air, it shall not count as a failure, provided the trial was otherwise made in accordance with this Rule. Nor shall it count as a failure if an athlete thereby loses his balance and as a result contravenes any

part of this Rule. In both cases the athlete shall be awarded a new trial.

The Hammer

4. Construction. The hammer shall consist of three main parts: a metal head, a wire and a handle.

5. Head. The head shall be of solid iron or other metal not softer than brass or a shell of such metal, filled with lead or other solid material.

If a filling is used, this shall be inserted in such manner that it is immovable and that the centre of gravity shall not be more than 6mm from the centre of the sphere.

6. Wire. The wire shall be a single unbroken and straight length of spring steel wire not less than 3mm in diameter and shall be such that it cannot stretch appreciably while the hammer is being thrown.

The wire may be looped at one or both ends as a means of attachment.

7. Handle. The handle shall be rigid and without hinging joints of any kind. The total deformation of the handle under a tension load of 3.8kN shall not exceed 3mm. It shall be attached to the wire in such a manner that it cannot be turned within the loop of the wire to increase the overall length of the hammer.

The handle may have a curved or straight grip with a maximum length inside of 110mm. The minimum handle breaking strength shall be 8kN.

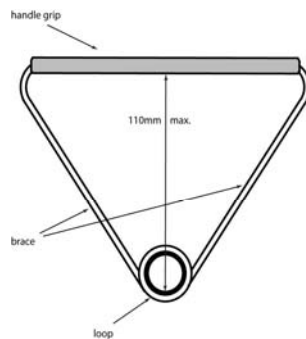

Figure 20 - Generic hammer handle

Note: Other designs complying with the specifications are acceptable.

8. Connections for wire. The wire shall be connected to the head by means of a swivel, which may be either plain or ball bearing. The handle shall be connected to the wire by means of a loop. A swivel may not be used.

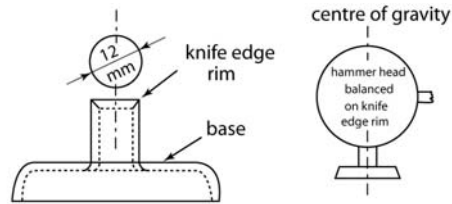

Figure 21 - Suggested apparatus for testing centre of gravity of hammer head

9. The hammer shall conform to the following specifications:

Hammer

Minimum weight for admission to competition and for acceptance of a Record

4.000kg	5.000kg	6.000kg	7.260kg
---------	---------	---------	---------

Information for manufacturers: Range for supply of implement for competition

4.005kg	5.005kg	6.005kg	7.265kg
4.025kg	5.025kg	6.025kg	7.285kg

Length of Hammer measured from inside of handle

Min.	1160mm	1165mm	1175mm
------	--------	--------	--------

1175mm

Max.	1195mm	1200mm	1215mm
------	--------	--------	--------

1215mm

Diameter of head

Min.	95mm	100mm	105mm	110mm
------	------	-------	-------	-------

Max.	110mm	120mm	125mm	130mm
------	-------	-------	-------	-------

Centre of gravity of head

It shall be not more than 6mm from the centre of the sphere, i.e. - it must be possible to balance the head, less handle and wire, on a horizontal sharp-edged circular orifice 12mm in diameter (see Figure 21).

RULE 192
Hammer Cage

1. All hammer throws shall be made from an enclosure or cage to ensure the safety of spectators, officials and athletes. The cage specified in this Rule is intended for use when the event takes place in the arena with other events taking place at the same time or when the event takes place outside the arena with spectators present. Where this does not apply, and especially in training areas, a much simpler construction may be satisfactory. Advice is available on request from national organisations or from the IAAF Office.
2. The cage should be designed, manufactured and maintained so as to be capable of stopping a 7.260kg hammer head moving at a speed of up to 32 metres per second. The arrangement should be such that there is no danger of ricocheting or rebounding back towards the athlete or over the top of the cage. Provided that it satisfies all the requirements of this Rule, any form of cage design and construction can be used.
3. The cage should be U-shaped in plan as shown on Figure 22. The width of the mouth should be 6m, positioned 7m in front of the centre of the throwing circle. The end points of the 6m wide mouth shall be the inner edge of the pivoted netting. The height of the netting panels or draped netting at their lowest point shall be at least 7m for the panels/netting at the rear of the cage and at least 10m for the last 2.80m panels to the gate pivot points. Provisions should be made in the design and construction of the cage to prevent a hammer forcing its way through any joints in the cage or the netting or underneath the netting panels or draped netting.
Note: The arrangement of the rear panels/netting is not important provided the netting is a minimum of 3.50m away from the centre of the circle.
4. Two movable netting panels 2m wide shall be provided at the front of the cage, only one of which will be operative at a time. The minimum height of the panels shall be 10m.
Note (i): The left hand panel is used for throwers turning anti clockwise, and the right hand panel for throwers turning clockwise. In view of the possible need to change over from one panel to the other during the competition, when both left and right-handed throwers are present, it is essential that this

changeover should require little labour and be carried out in the minimum of time.

Note (ii): The end position of both panels is shown in the plan even though only one panel will be closed at any one time during competition.

Note (iii): When in operation, the movable panel shall be exactly in the position shown. Provision shall therefore, be made in the design of the movable panels to lock them in the operative position. It is recommended to mark (either temporarily or permanently) the operative positions of the panels on the ground.

Note (iv): The construction of these panels and their operation depends on the overall design of the cage and can be sliding, hinging on a vertical or horizontal axis or dismounting. The only firm requirements are that the panel in operation shall be fully able to stop any hammer striking it and there shall be no danger of a hammer being able to force its way between the fixed and movable panels.

Note (v): Innovative designs that provide the same degree of protection and do not increase the danger zone compared with conventional designs may be IAAF Certified.

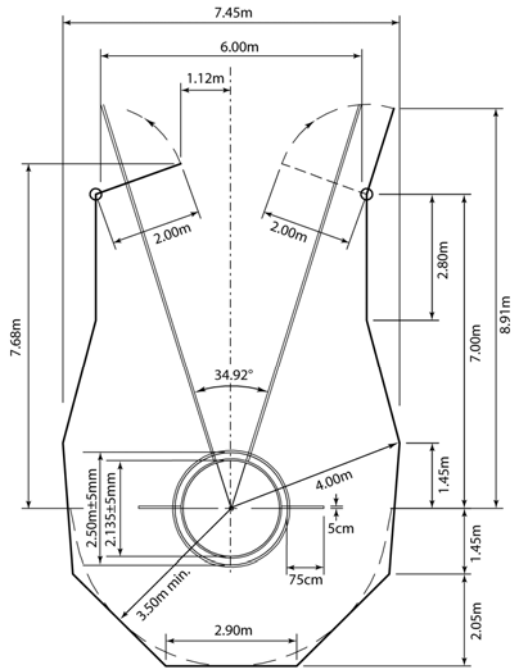

Figure 22 - Cage for Hammer and Discus Throw with concentric circles
(Hammer Throw configuration)

5. The netting for the cage can be made from suitable natural or synthetic fibre cord or, alternatively, from mild or high tensile steel wire. The maximum mesh size shall be 44mm for cord netting and 50mm for steel wire.
Note: Further specifications for the netting and safety inspection procedures are set out in the IAAF Track and Field Facilities Manual.
6. Where it is desired to use the same cage for Discus Throw, the installation can be adapted in two alternative ways. Most simply, a 2.135/2.500m concentric circle may be fitted, but this involves using the same surface in the circle for Hammer Throw and Discus Throw. The hammer cage shall be used for Discus Throw by fixing the movable netting panels clear of the cage opening.

For separate circles for Hammer Throw and Discus Throw in the same cage, the two circles shall be placed one behind the other with the centres 2.37m apart on the centre line of the landing sector and with the discus circle at the front. In that case, the movable netting panels shall be used for Discus Throw.

Note: The arrangement of the rear panels/draped netting is not important provided the netting is a minimum of 3.50m away from the centre of concentric circles or the hammer circle in case of separate circles (or 3.00m for cages with separate circles built under the Rule in force before 2004 with the discus circle at the back) (see also Rule 192.4).

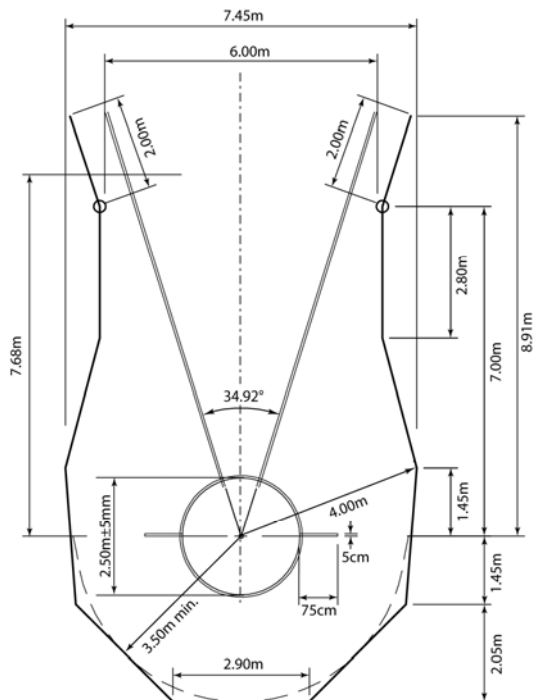

Figure 23 - Cage for Hammer and Discus Throw with concentric circles
(Discus Throw configuration)

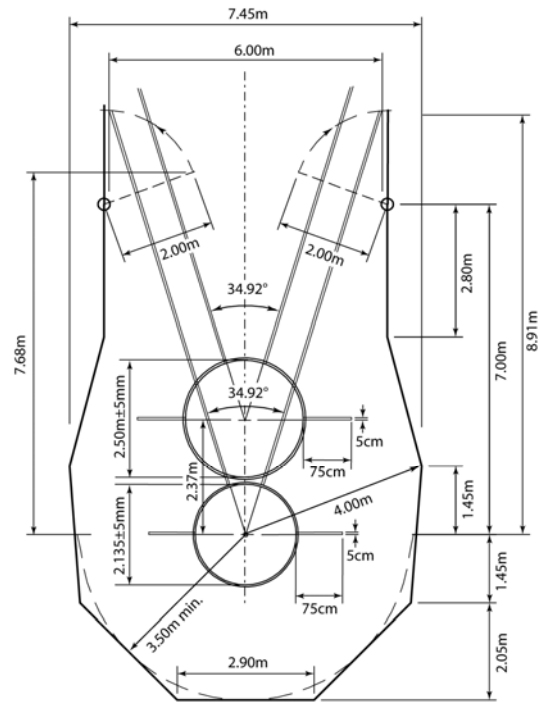

Figure 24 - Cage for Hammer and Discus Throw with separate circles

7. The maximum danger sector for hammer throws from this cage is approximately 53° , when used by both right and left-handed throwers in the same competition. The position and alignment of the cage in the arena is, therefore, critical for its safe use.

RULE 193
Javelin Throw

The Competition

1. (a) The javelin shall be held at the grip. It shall be thrown over the shoulder or upper part of the throwing arm and shall not be slung or hurled. Non-orthodox styles are not permitted.
(b) A throw shall be valid only if the tip of the metal head strikes the ground before any other part of the javelin.
(c) Until the javelin has been thrown, an athlete shall not at any time turn completely around, so that his back is towards the throwing arc.
2. If the javelin breaks during a throw or while in the air, it shall not count as a failure, provided the trial was otherwise made in accordance with this Rule. Nor shall it count as a failure if an athlete thereby loses his balance and as a result contravenes any part of this Rule. In both cases the athlete shall be awarded a new trial.

The Javelin

3. Construction. The javelin shall consist of three main parts: a head, a shaft and a cord grip. The shaft may be solid or hollow and shall be constructed of metal or other suitable material so as to constitute a fixed and integrated whole. The shaft shall have fixed to it a metal head terminating in a sharp point.
The surface of the shaft shall have no dimples or pimples, grooves or ridges, holes or roughness, and the finish shall be smooth (see Rule 188.4) and uniform throughout.
The head shall be constructed completely of metal. It may contain a reinforced tip of other metal alloy welded on to the front end of the head provided that the completed head is smooth (see Rule 188.4) and uniform along the whole of its surface.
4. The grip, which shall cover the centre of gravity, shall not exceed the diameter of the shaft by more than 8mm. It may have a regular non-slip pattern surface but without thongs, notches or indentations of any kind. The grip shall be of uniform thickness.
5. The cross-section shall be regularly circular throughout (see Note (i)). The maximum diameter of the shaft shall be immediately in front of the grip. The central portion of the shaft, including the part under the grip, may be cylindrical or slightly tapered towards the rear but in no case may the reduction in diameter, from immediately in front of the grip to immediately behind, exceed 0.25mm. From the grip, the javelin shall taper regularly to the tip

at the front and the tail at the rear. The longitudinal profile from the grip to the front tip and to the tail shall be straight or slightly convex (see Note (ii)), and there shall be no abrupt alteration in the overall diameter, except immediately behind the head and at the front and rear of the grip, throughout the length of the javelin. At the rear of the head, the reduction in the diameter may not exceed 2.5mm and this departure from the longitudinal profile requirement may not extend more than 300mm behind the head.

Note (i): Whilst the cross section should be circular, a maximum difference between the largest and the smallest diameter of 2% is permitted. The mean value of these two diameters shall correspond to the specifications of a circular javelin.

Note (ii): The shape of the longitudinal profile may be quickly and easily checked using a metal straight edge at least 500mm long and two feeler gauges 0.20mm and 1.25mm thick. For slightly convex sections of the profile, the straight edge will rock while being in firm contact with a short section of the javelin. For straight sections of the profile, with the straight edge held firmly against it, it must be impossible to insert the 0.20mm gauge between the javelin and the straight edge anywhere over the length of contact. This shall not apply immediately behind the joint between the head and the shaft. At this point it must be impossible to insert the 1.25mm gauge.

6. The javelin shall conform to the following specifications:

Javelin

Minimum weight for admission to competition and for acceptance of a Record (inclusive of the cord grip)		600g	700g	800g
Information for manufacturers: Range for supply of implement for competition		605g	705g	805g
		625g	725g	825g
Overall length	Min.	2.20m	2.30m	2.60m
	Max.	2.30m	2.40m	2.70m
Length of metal head	Min.	250mm	250mm	250mm
	Max.	330mm	330mm	330mm
Distance from tip of metal head to centre of gravity				
	Min.	0.80m	0.86m	0.90m
	Max.	0.92m	1.00m	1.06m
Diameter of shaft at thickest point				
	Min.	20mm	23mm	25mm

	Max.	25mm	28mm	30mm
Width of cord grip	Min.	140mm	150mm	150mm
	Max.	150mm	160mm	160mm

Javelin

7. The javelin shall have no mobile parts or other apparatus, which during the throw could change its centre of gravity or throwing characteristics.
8. The tapering of the javelin to the tip of the metal head shall be such that the angle of the point shall be not more than 40°. The diameter, at a point 150mm from the tip, shall not exceed 80% of the maximum diameter of the shaft. At the midpoint between the centre of gravity and the tip of the metal head, the diameter shall not exceed 90% of the maximum diameter of the shaft.
9. The tapering of the shaft to the tail at the rear shall be such that the diameter, at the midpoint between the centre of gravity and the tail, shall not be less than 90% of the maximum diameter of the shaft. At a point 150mm from the tail, the diameter shall be not less than 40% of the maximum diameter of the shaft. The diameter of the shaft at the end of the tail shall not be less than 3.5mm.

Lengths (all dimensions mm)

Serial	Men		Women	
	Max	Min	Max	Min
LO	Overall	2700	2600	2300
L1	Tip to C of G	1060	900	800
1/2L1	Half L1	530	450	400
L2	Tail to C of G	1800	1540	1500
1/2L2	Half L2	900	770	750
L3	Head	330	250	330
L4	Grip	160	150	150

Diameters (all dimensions mm)

Serial	Men		Women	
	Detail	Max	Detail	Min
DO	In front of grip	30	25	20
D1	At rear of grip	-	DO-0.25	DO-0.25
D2	150mm from tip	0.8 DO	-	0.8 DO
D3	At rear of head	-	-	-
D4	Immediately behind head	-	D3-2.5	-
D5	Half way tip to C of G	0.9 DO	-	0.9 DO
D6	Over grip	DO + 8	-	DO + 8
D7	Half way tail to C of G	-	0.9 DO	-
D8	150mm from tail	-	0.4 DO	-
D9	At tail	-	3.5	-

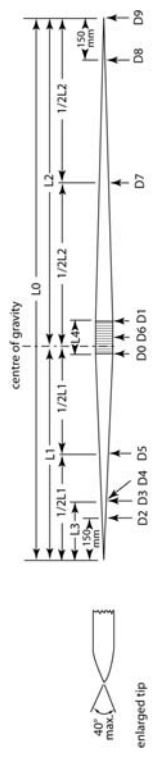

Figure 25 - International Javelin

SECTION V - COMBINED EVENTS COMPETITIONS

RULE 200

Combined Events Competitions

MEN JUNIOR AND SENIOR (Pentathlon and Decathlon)

1. The Pentathlon consists of five events which shall be held on one day in the following order: Long Jump; Javelin Throw; 200m; Discus Throw; and 1500m.
2. The Men's Decathlon consists of ten events which shall be held on two consecutive days in the following order:

First day: 100m; Long Jump; Shot Put; High Jump and 400m.

Second day: 110m Hurdles; Discus Throw; Pole Vault; Javelin Throw and 1500m.

WOMEN JUNIOR AND SENIOR (Heptathlon and Decathlon)

3. The Heptathlon consists of seven events, which shall be held on two consecutive days in the following order:

First day: 100m Hurdles; High Jump; Shot Put and 200m.

Second day: Long Jump; Javelin Throw and 800m.

4. The Women's Decathlon consists of ten events which shall be held on two consecutive days in the following order:

First day: 100m; Discus Throw; Pole Vault; Javelin Throw and 400m.

Second day: 100m Hurdles; Long Jump; Shot Put; High Jump and 1500m.

BOYS YOUTH (Octathlon)

5. The Octathlon consists of eight events, which shall be held on two consecutive days in the following order:

First day: 100m; Long Jump; Shot Put and 400m.

Second day: 110m Hurdles; High Jump; Javelin Throw and 1000m.

GIRLS YOUTH (Heptathlon)

6. The Heptathlon consists of seven events, which shall be held on two consecutive days in the following order:

First day: 100m Hurdles; High Jump; Shot Put and 200m.

Second day: Long Jump; Javelin Throw and 800m.

General

7. At the discretion of the Combined Events Referee, there shall, whenever possible, be an interval of at least 30 minutes between the time one event ends and the next event begins, for any individual athlete. If possible, the time between the finish of the last event on the first day and the start of the first event on the second day should be at least 10 hours.
8. In each separate event, except the last, of a Combined Event competition, the heats and groups shall be arranged by the Technical Delegate(s) or Combined Events Referee, as applicable, so that the athletes with similar performances in each individual event during a predetermined period, shall be placed in the same heat or group. Preferably five or more, and never less than three, athletes shall be placed in each heat or group. When this cannot be achieved because of the timetable of events, the heats or groups for the next event should be arranged as and when athletes become available from the previous event. In the last event of Combined Events Competition, the heats should be arranged so that the last one contains the leading athletes after the penultimate event. The Technical Delegate(s) or the Combined Events Referee shall have the authority to rearrange any group if, in his opinion, it is

desirable.

9. The Rules for each event constituting the competition will apply with the following exceptions:
 - (a) in the Long Jump and each of the throwing events, each athlete shall be allowed three trials only.
 - (b) in case Fully Automatic Timing is not available, each athlete's time shall be taken by three Timekeepers independently.
 - (c) in the track events, an athlete shall be disqualified in any event in which he has made two false starts.
10. Only one system of timing may be applied throughout each event. However, for Record purposes, times obtained from a Fully Automatic Photo Finish system shall be applied regardless of whether such times are available for other athletes in the event.
11. Any athlete failing to attempt to start or make a trial in one of the events shall not be allowed to take part in the subsequent events but shall be considered to have abandoned the competition. He shall not, therefore, figure in the final classification.
Any athlete deciding to withdraw from a Combined Events Competition shall immediately inform the Combined Events Referee of his decision.
12. The scores, according to the current IAAF Scoring Tables, shall be announced, separate for each event and as a cumulative total, to all athletes after the completion of each event.
The winner shall be the athlete who has obtained the highest total number of points.
13. In the event of a tie, the winner shall be the athlete who, in the greater number of events, has received more points than the other athlete(s) tying. If this does not resolve the tie, the winner shall be the athlete who has the highest number of points in any one event and if that does not resolve the tie, the winner shall be the one with the highest number of points in a second event, etc. This shall also apply to ties for any other place in the competition.

SECTION VI - INDOOR COMPETITIONS

RULE 210

Applicability of Outdoor Rules to Indoor Competitions

With the exceptions stated in the following Rules of this Section VI, the Rules of Sections I to V for outdoor competitions shall apply to Indoor Competitions.

RULE 211

The Indoor Stadium

1. The stadium shall be completely enclosed and covered. Lighting, heating and ventilation shall be provided to give satisfactory conditions for competition.
2. The arena should include an oval track; a straight track for sprints and hurdles; runways and landing areas for jumping events. In addition, a circle and landing sector for the Shot Put should be provided, whether permanently or temporarily. All the facilities should conform to the specifications in the IAAF Track and Field Facilities Manual.
3. All the tracks, runways or take-off surface areas shall be covered with a synthetic material or have a wooden surface. The former should preferably be able to accept 6mm spikes in running shoes. Alternative thicknesses may be provided by the stadium management, who will notify athletes of the permissible length of spikes. (See Rule 143.4).

Indoor Track and Field competitions under Rules 1.1(a), (b), (c), and (f) should be held only on facilities that have a current IAAF Indoor Athletics Facility Certificate.

It is recommended that, when such facilities are available, competitions under Rules 1.1(d), (e), (g), (h), (i) and (j) should also be held on these facilities.

4. The foundation on which the synthetic surface of the tracks, runways and take-off areas is laid shall be either solid e.g. concrete or, if of suspended construction (such as wooden boards or plywood sheets mounted on joists), without any special sprung sections and, as far as technically possible, each runway shall have a uniform resilience throughout. This shall be checked, for the take-off area for the jumps, before each competition.

Note (i): A "sprung section" is any deliberately engineered or constructed section designed to give extra assistance to a competitor.

Note (ii): The IAAF Track and Field Facilities Manual contains more detailed and defined specifications for planning and construction of indoor stadia.

Note (iii): Standard forms of Facility Certification Application and Indoor Track and Field Facilities Measurement Report are available, on request, from the IAAF Office or may be downloaded from the IAAF website.

RULE 212

The Straight Track

1. The lateral inclination of the track shall not exceed 1:100 and the inclination in the running direction shall not exceed 1:250 at any point and 1:1000 overall.

Lanes

2. The track should have a minimum of 6 and a maximum of 8 lanes separated and bounded on both sides by white lines 5cm wide. The lanes shall all be 1.22m \pm 0.01m wide including the lane line on the right.

Note: For all tracks constructed before 1 January 2004, the lanes may have a width of maximum 1.25m.

The Start and Finish

3. There should be a clearance of at least 3m behind the start line free of any obstruction. There shall be a clearance of at least 10m beyond the finish line free of any obstruction with adequate provision beyond for an athlete to come to a halt without injury.

Note: It is strongly recommended that the minimum clearance beyond the finish line should be 15m.

RULE 213

The Oval Track and Lanes

1. The nominal length should preferably be 200m. It shall consist of two parallel straights and two bends, which may be banked, whose radii should be equal.

The inside of the track shall be bordered either with a kerb of suitable material, approximately 5cm in height and width, or with a white line 5cm wide. The outside edge of this kerb or line forms the inside of lane 1. The inside edge of the line or kerb shall be horizontal throughout the length of the track with a maximum slope of 1:1000.

Lanes

2. The track should have a minimum of four and a maximum of six lanes.
The lanes should all have the same width with a minimum of 0.90m and a maximum of 1.10m including the lane line on the right. The lanes shall be separated by white lines 5cm wide.

Banking

3. The angle of banking in all the lanes should be the same at any cross section of the track.
In order to ease the change from the flat straight to the banked bend, the change may be made with a smooth gradual horizontal transition which may be extended into the straight. In addition, there should be a vertical transition.

Marking of the Inside Edge

4. Where the inside edge of the track is bordered with a white line, it shall be marked additionally with cones or flags. The cones shall be at least 20cm high. The flags shall be approximately 25cmx20cm in size, at least 45cm high and set at an angle of 60° with the ground away from the track. The cones or flags shall be placed on the white line so that the edge of the base of the cone or flag pole coincides with the edge of the white line closest to the track. The cones or flags shall be placed at distances not exceeding 1.5m on the bends and 10m on the straights.

Note: For all indoor competitions directly under the IAAF, the use of an inside kerb is strongly recommended.

RULE 214

Start and Finish on the Oval Track

1. Technical information on the construction and marking of a 200m banked indoor track are given in detail in the IAAF Track and Field Facilities Manual. The basic principles to be adopted are given hereunder.

Basic Requirements

2. The start and finish of a race shall be denoted by white lines 5cm wide, at right angles to the lane lines for straight parts of the track and along a radius line for curved parts of the track.
3. The requirements for the finish line are that, if at all possible there should be only one for all the different lengths of race, that it shall be on a straight part of the track and that as much of that

straight as possible should be before the finish.

4. The essential requirement for all start lines, straight, staggered or curved, is that the distance for every athlete, when taking the shortest permitted route, shall be the same.
5. As far as possible, start lines (and take-over zone lines for relay races) should not be on the steepest part of the banking.

Conduct of the Races

6. For races of 400m or less, each athlete shall have a separate lane at the start. Races of up to, and including, 300m shall be run entirely in lanes. Races over 300m, and less than 800m shall start and continue in lanes until the end of the second bend. In races of 800m each athlete may be assigned a separate lane or a group start preferably using lane 1 and 3 may be used. Races longer than 800m shall be run without lanes using an arced start line or group starts.

Note (i): In competitions other than those held under Rules 1.1(a), (b), (c) and (f), the Members concerned may agree not to use lanes for the 800m event.

Note (ii): On tracks with less than six lanes, a group start as in Rule 162.9 may be used to allow six athletes to compete.

The Start Line and the Finish Line for a Track of 200m nominal length

7. The start line in lane 1 should be on the principal straight. Its position shall be determined so that the most advanced staggered start line in the outside lane (400m races, see Rule 214.9) should be in a position where the angle of banking should not be more than 12 degrees.
The finish line for all races on the oval track shall be an extension of the start line in lane 1, right across the track and at right angles to the lane lines.

Staggered Start Line for a 200m Race

8. The position of the start line in lane 1 and the position of the finish line having been established, the position of the start lines in the remaining lanes should be determined by measurement in each lane back from the finish line. Measurement in each lane shall be carried out in exactly the same way as for lane 1 when measuring the length of the track (See Rule 160.2).
Having established the position of the start line where it intersects the measurement line 20cm outward from the inside of the lane, the line shall be extended right across the lane, at right angles to the lane lines if on a straight section of the track. If on a curved

section of the track, the line of the position to be measured shall be drawn along a radius line through the centre of the bend and if on one of the transition sections (See Rule 213.4) along a radius line through the theoretical centre of curvature at that point. The start line can then be marked 5cm wide, on the side of the measured position nearer the finish.

Staggered Start Lines for Races over 200m, up to and including 800m

9. As the athletes are permitted to leave their respective lanes on entering the straight after running one or two bends in lanes, the starting positions shall take two factors into consideration. Firstly, the normal echelon allowance similar to that for a 200m race (See Rule 214.8). Secondly, an adjustment to the starting line in each lane to compensate for the athletes in outside lanes having farther to go than those in the inside lanes to reach the inside position at the end of the straight after the breakline. These adjustments can be determined when marking out the breakline, where the athletes are allowed to leave their lanes. Unfortunately, since start lines are 5cm wide, it is impossible to mark two different start lines unless the difference in position is in excess of approximately 7cm to allow a clear gap of 2cm between the start lines. Where this problem arises, the solution is to use the rearmost start line. The problem does not arise in lane 1 since, by definition, there is no adjustment for the breakline. It arises in the inner lanes (i.e. 2 and 3) but not in the outer lanes (i.e. 5 and 6) where the adjustment due to the breakline is greater than 7cm. In those outer lanes where the separation is sufficient, a second start line can be measured in front of the first one by the required "adjustment" determined from the breakline layout. The second start line can then be marked out in the same way as that for the 200m race. It is the position of this start line in the outside lane which determines the position of all the start lines and the finish line on the track. In order to avoid exposing the athlete starting in the outside lane to the very severe disadvantage of starting on a steeply banked track, all the start lines and hence the finish line are moved sufficiently far back from the first bend so as to restrict the steepness of the banking to an acceptable level. It is, therefore, necessary first to fix the position of the 400m and 800m start lines in the outside lane and then work back through all the other start lines, finally arriving at the finish line. To assist athletes identify the breakline small cones or prisms,

- II 5cmx5cm and no more than 15cm high, preferably of different colour from the breakline and the lane lines, shall be placed on the lane lines immediately before the intersection of the lane lines and the breakline.

Qualification from Preliminary Heats

10. In indoor competitions, the following tables shall, in the absence of extraordinary circumstances, be used to determine the number of rounds and the number of heats in each round to be held and the qualification procedure for each round of track events:

60m, 60m H

Declared Entries	Qualifying R1			Qualifying R2		
	Heats	P	T	Heats	P	T
9-16	2	3	2			
17-24	3	2	2			
25-32	4	3	4	2	4	
33-40	5	4	4	3	2	2
41-48	6	3	6	3	2	2
49-56	7	3	3	3	2	2
57-64	8	2	8	3	2	2
65-72	9	2	6	3	2	2
73-80	10	2	4	3	2	2

200m, 400m, 800m, 4x200m, 4x400m

Declared Entries	Qualifying R1			Qualifying R2		Qualifying R3	
	Heats	P	T	Heats	P	Heats	P
7-12	2	2	2				
13-18	3	3	3	2	3		
19-24	4	2	4	2	3		
25-30	5	2	2	2	3		
31-36	6	2	6	3	2		
37-42	7	2	4	3	2		
43-48	8	2	2	3	2		
49-54	9	2	6	4	3	2	3
55-60	10	2	4	4	3	2	3

1500m

Declared Entries	Qualifying R1			Qualifying R2		
	Heats	P	T	Heats	P	T
12-18	2	3	3			
19-27	3	2	3			
28-36	4	2	1			
37-45	5	3	3	2	3	3

46-54	6	2	6	2	3	3
55-63	7	2	4	2	3	3

3000 m

Declared Entries	Qualifying R1	
	Heats P	T
16-24	2	4
25-36	3	3
37-48	4	2

Note: The above qualifying procedures are only valid for 6 lanes oval tracks and/or 8 lanes straight tracks.

Draw for Lanes

11. For all events other than 800m, run wholly or partly in lanes around a bend, where there are successive rounds of a race, a draw for lanes will be made for:
 - (a) the outer two lanes between the two highest ranked athletes or teams;
 - (b) the next two lanes between the third and fourth ranked athletes or teams;
 - (c) any remaining inner lanes between the other athletes or teams.

The ranking referred to shall be determined as follows:

 - (d) for first round heats from the relevant list of valid performances achieved during the predetermined period.
 - (e) for subsequent round or final in accordance with the procedures identified in Rule 166.3(a).
12. For all other races the lane order shall be drawn in accordance with Rules 166.4 and 166.8.

RULE 215

Clothing, Shoes and Number Bibs

When a competition is conducted on a synthetic surface, that part of each spike which projects from the sole or the heel shall not exceed 6mm (or as required by the Organising Committee).

RULE 216

Hurdle Races

-
1. Hurdle races shall be conducted over distances of 50m or 60m on the straight track.
 2. Layout of the hurdles for races:

	Youth Boys	Junior Men	Men	Youth Girls	Jr. Women/ Women
Height of hurdle	0.914m	0.990m	1.067m	0.762m	0.840m
Distance	50m/60m				
Number of hurdles	4/5				
Start line to first hurdle	13.72m			13.00m	
Between hurdles	9.14m			8.50m	
Last hurdle to finish line	8.86m/9.72m			11.50m/13.00m	

RULE 217

Relay Races

Conduct of the Races

1. In the 4x200m relay race all the first leg and the first bend of the second leg shall be run in lanes. At the end of this bend, there shall be a 5cm wide line (breakline) distinctively marked across all the lanes at this point to indicate where each athlete can break from his lane. Rule 170.7 shall not apply.
2. In the 4x400m relay race, the first two bends shall be run in lanes. Thus the same breakline, scratch lines etc. will be used as for the individual 400m race.
3. In the 4x800m relay race, the first bend shall be run in lanes. Thus the same breakline, scratch lines etc. will be used as for the individual 800m race.
4. In relay races where athletes are permitted to leave their respective lanes on entering the straight after running two or three bends in lanes, the layout for the echelon start is described in Rule 214.9.
5. The waiting athletes in the third and fourth legs of the 4x200m relay race, in the second, third and fourth legs of the 4x400m and the 4x800m relay race shall, under the direction of a designated official, place themselves in their waiting position in the same order (inside to out) as the order of their respective team members as they enter the last bend. Once the incoming athletes have passed this point, the waiting athletes shall maintain their order, and shall not exchange positions at the beginning of the take-over zone. If an athlete does not follow this Rule, his team shall be disqualified.

Note: Owing to the narrow lanes, indoor relay races are much

more liable to collisions and unintended obstruction than outdoor relay races. It is, therefore, recommended that, when possible, a spare lane should be left between each team.

RULE 218
High Jump

The Runway and Take-Off Area

1. If portable mats are used, all references in the Rules to the level of the take-off area must be construed as referring to the level of the top surface of the mat.
2. An athlete may start his approach on the banking of the oval track provided that the last 15m of his run up is on a runway complying with Rules 182.3, 182.4 and 182.5.

RULE 219
Pole Vault

The Runway

An athlete may start his approach on the banking of the oval track provided that the last 40m of his run up is on a runway complying with Rules 183.6 and 183.7.

RULE 220
Horizontal Jumps

The Runway

An athlete may start his approach on the banking of the oval track provided that the last 40m of his run up is on a runway complying with Rules 184.2 and 184.3.

RULE 221
Shot Put

Shot Landing Sector

1. The landing sector shall consist of some suitable material on which the shot will make an imprint, but which will minimise any bounce.
2. The landing sector shall be enclosed at the far end and on the two sides, as close to the circle as may be necessary for safety of the other athletes and officials, by a stop barrier and protective netting of approximately 4m height which should stop a shot whether in flight or bouncing from the landing surface.
3. In view of the limited space inside an indoor arena, the area

enclosed by the stop barrier may not be large enough to include a full 34.92° sector. The following conditions shall apply to any such restriction.

- (a) The stop barrier at the far end shall be at least 50cm beyond the current World Record in Shot Put for men or women.
- (b) The sector lines on either side shall be symmetrical about the centre line of the 34.92° sector.
- (c) The sector lines may either run radially from the centre of the Shot Put circle including a full 34.92° sector, or may be parallel to each other and the centre line of the 34.92° sector. Where the sector lines are parallel, the minimum separation of the two sector lines shall be 9m.

Construction of the Shot

4. Depending on the type of landing area (see Rule 221.1), the shot shall be either solid metal or metal cased or alternatively soft plastic or rubber cased with a suitable filling. Both types of shot may not be used in the same competition.

Solid Metal or Metal Cased Shot

5. These shall comply with Rule 188.4 and 188.5, for the Shot Put outdoors.

Plastic or Rubber Cased Shot

6. The shot shall have a soft plastic or rubber case with a suitable filling such that no damage shall be caused when landing on a normal sports hall floor. It shall be spherical in shape and its surface shall have no roughness and the finish shall be smooth.

The shot shall conform to the following specifications:

SHOT

Minimum weight for admission to competition and for acceptance of a Record

4.000kg 7.260kg

Information for manufacturers: Range for supply of implement for competition

4.005kg 7.265kg

4.025kg 7.285kg

Diameter Minimum

95mm 110mm

Diameter Maximum

130mm 145mm

RULE 222

Combined Events Competitions

Men (Pentathlon)

1. The Pentathlon consists of five events, which shall be held on one day in the following order:
60m Hurdles, Long Jump, Shot Put, High Jump, 1000m.

Men (Heptathlon)

2. The Heptathlon consists of seven events which shall be held over two consecutive days in the following order:
First day: 60m, Long Jump, Shot Put, High Jump.
Second day: 60m Hurdles, Pole Vault, 1000m.

Women (Pentathlon)

3. The Pentathlon consists of five events and shall be held on one day in the following order:
60m Hurdles, High Jump, Shot Put, Long Jump, 800m.

Heats and Groups

4. Preferably four or more, and never less than three, athletes shall be placed in each heat or group.

SECTION VII - RACE WALKING EVENTS**RULE 230
Race Walking**

Definition of Race Walking

1. Race Walking is a progression of steps so taken that the walker makes contact with the ground, so that no visible (to the human eye) loss of contact occurs. The advancing leg shall be straightened (i.e. not bent at the knee) from the moment of first contact with the ground until the vertical upright position.

Judging

2. (a) The appointed judges of Race Walking shall elect a Chief Judge, if one has not been appointed previously.
 - (b) All the Judges shall act in an individual capacity and their judgements shall be based on observations made by the human eye.
 - (c) In competitions held under Rule 1.1(a), all Judges shall be International Race Walking Judges. In competitions held under Rules 1.1(b), (c), (e)(ii), (f), (g) and (j), all Judges shall be either Area or International Race Walking Judges.
 - (d) For road races, there should normally be a minimum of six to a maximum of nine Judges including the Chief Judge.
 - (e) For track races, there should normally be six Judges including the Chief Judge.
 - (f) In competitions held under Rule 1.1(a) not more than one Judge from any country can officiate.

Chief Judge

3. (a) In competitions held under Rules 1.1(a), (b), (c), (d) and (f), the Chief Judge has the power to disqualify an athlete inside the stadium when the race finishes in the stadium or in the last 100m when the race takes place solely on the track or on the road course, when his/her mode of progression obviously fails to comply with the Rule 230.1 regardless of the number of previous Red Cards the Chief Judge has received on that athlete. An athlete who is disqualified by the Chief Judge under these circumstances shall be allowed to finish the race.
 - (b) The Chief Judge shall act as the supervising official for the competition, and act as a Judge only in the special situation

noted in Rule 230.3(a) in competitions under Rules 1.1(a), (b), (c), (d) and (f). In competitions held under Rules 1.1(a), (b) (c) and (f), a maximum of two Chief Judge's Assistants shall be appointed. The Chief Judge's Assistant(s) are to assist with the notification of disqualifications only and shall not act as Race Walking Judges.

- (c) For all competitions held under Rules 1.1(a), (b), (c) and (f), an official in charge of the Posting Board(s) and a Chief Judge's Recorder shall be appointed.

Caution

- 4. Athletes shall be cautioned when, by their mode of progression, they are in danger of failing to comply with Rule 230.1 by showing the athletes a yellow paddle with the symbol of the offence on each side.

An athlete cannot be given a second caution by the same Judge for the same offence. Having cautioned an athlete, the Judge shall inform the Chief Judge of his action after the competition.

Red Cards

- 5. When a Judge observes an athlete failing to comply with Rule 230.1 by exhibiting visible loss of contact or a bent knee during any part of the competition, the Judge shall send a Red Card to the Chief Judge.

Disqualification

- 6.
 - (a) When three Red Cards from three different Judges have been sent to the Chief Judge on the same athlete, the athlete is disqualified and he shall be notified of this disqualification by the Chief Judge or a Chief Judge's Assistant by showing the athlete a red paddle. The failure to give notification shall not result in the reinstatement of a disqualified athlete.
 - (b) In all competitions, either directly controlled by the IAAF or taking place under IAAF permit, in no circumstances shall the Red Cards of two Judges of the same nationality have the power to disqualify.
 - (c) In track races, an athlete who is disqualified shall immediately leave the track and, in road races, shall, immediately after being disqualified, remove the distinguishing numbers and leave the course. Any disqualified athlete who fails to leave the course or track may be liable to further disciplinary action in accordance with Rules 22.1(f) and 145.2.

- (d) One or more Posting Boards shall be placed on the course and near the finish to keep athletes informed about the number of Red Cards that have been sent to the Chief Judge for each athlete. The symbol of each offence should also be indicated on the Posting Board.
- (e) For all Rule 1.1(a) competitions, hand held computer devices with transmission capability must be used by the judges to communicate all Red Cards to the Recorder and the Posting Board(s).

The Start

7. The races shall be started by the firing of a gun. The commands and procedure for races longer than 400m shall be used (Rule 162.3). In races which include a large number of athletes, a five-minute warning before the start of the race should be given, with additional warnings if required.

Safety and Medical

8. (a) The Organising Committee of Race Walking events shall ensure the safety of athletes and officials. In competitions held under Rules 1.1(a), (b), (c) and (f), the Organising Committee shall ensure that the roads used for the competition are closed to motorised traffic in all directions.
- (b) In competitions held under Rules 1.1(a), (b), (c) and (f), the events shall be scheduled to start and finish in daylight.
- (c) A hands-on medical examination during the progress of an event by the official medical staff appointed by the Organising Committee and identified by armbands, vests or similar distinctive apparel shall not be considered assistance.
- (d) An athlete shall retire at once from the race if ordered to do so by the Medical Delegate or a member of the official medical staff.

Drinking/Sponging and Refreshment Stations

9. (a) Water and other suitable refreshments shall be available at the start and finish of all races.
- (b) For all events up to and including 10km, drinking/sponging stations shall be provided at suitable intervals if weather conditions warrant such provision.
- (c) For all events longer than 10km, refreshment stations shall be provided every lap. In addition, drinking/sponging stations for water only shall be placed approximately midway between the refreshment stations or more frequently

- if weather conditions warrant such provision.
- (d) Refreshments, which may be provided by either the Organising Committee or the athlete, shall be placed at the stations so that they are easily accessible to, or may be put by authorised persons into the hands of, the athletes.
 - (e) An athlete who collects refreshment from a place other than the refreshment stations renders himself liable to disqualification by the Referee.
 - (f) In competitions held under Rules 1.1(a), (b), (c) and (f), a maximum of two officials per country may be stationed behind the refreshment table at any one time. No official shall, under any circumstances, run beside an athlete while he is taking refreshment.

Road Courses

- 10. (a) For competitions held under Rule 1.1(a), the circuit shall be no shorter than 2km and no longer than 2.5km. For all other competitions, the circuit shall be no shorter than 1 km and no longer than 2.5 km. For events that start and finish in the stadium, the circuit should be located as close as possible to the stadium.
- (b) Road courses shall be measured in accordance with Rule 240.3.

Race Conduct

- 11. In events of 20km or more, an athlete may leave the road or track with the permission and under the supervision of an official, provided that by going off course he does not lessen the distance to be covered.
- 12. If the Referee is satisfied on the report of a Judge or Umpire or otherwise that an athlete has left the marked course thereby shortening the distance to be covered, he shall be disqualified.

SECTION VIII - ROAD RACES

RULE 240

Road Races

Distances

1. The standard distances for men and women shall be 10km, 15km, 20km, Half-Marathon, 25km, 30km, Marathon (42.195km), 100km and Road Relay.

Note (i): It is recommended that the Road Relay race be run over the Marathon distance, ideally over a 5km loop course, with stages of 5km, 10km, 5km, 10km, 5km, 7.195km. For a junior Road Relay, the recommended distance is a Half-Marathon with stages of 5km, 5km, 5km, 6.098km.

Note (ii): It is recommended that road races be staged during April, May, or September to December, inclusive.

The Course

2. The races shall be run on made-up roads. However, when traffic or similar circumstances make it unsuitable, the course, duly marked, may be on a bicycle path or footpath alongside the road, but not on soft ground such as grass verges or the like. The start and finish may be within an athletic arena.

Note: It is recommended that, for road races staged over standard distances, the start and finish points, measured along a theoretical straight line between them should not be further apart than 50% of the race distance.

3. The start and the finish of a race shall be denoted by a white line at least 5cm wide. In events on roads the course shall be measured along the shortest possible route that an athlete could follow within the section of the road permitted for use in the race. In all competitions under Rules 1.1(a) and, where possible, (b), (c) and (f), the measurement line should be marked along the course in a distinctive colour that cannot be mistaken for other markings.

The length of the course shall not be less than the official distance for the event. In competitions under Rules 1.1(a), (b), (c) and (f), the uncertainty in the measurement shall not exceed 0.1% (i.e. 42m for the Marathon) and the length of the course should have been certified in advance by an IAAF approved course measurer.

Note (i): For measurement, the "Calibrated Bicycle Method" shall be used.

Note (ii): To prevent a course from being found to be short on

future re-measurement, it is recommended that a "short course prevention factor" be built in when laying out the course. For bicycle measurements this factor should be 0.1% which means that each km on the course will have a "measured length" of 1001m.

Note (iii): If it is intended that parts of the course on race day will be defined by the use of non-permanent equipment such as cones, barricades, etc. their positioning shall be decided not later than the time of the measurement and the documentation of such decisions shall be included in the measurement report.

Note (iv): It is recommended that for Road Races staged over standard distances, the overall decrease in elevation between the start and finish should not exceed 1:1000, i.e. 1m per km.

Note (v): A course measurement certificate is valid for five years, after which the course shall be re-measured even when there are no obvious changes to it.

4. The distance in kilometres on the route shall be displayed to all athletes.
5. For Road Relays, lines 5cm wide shall be drawn across the course to mark the distances of each stage and to denote that scratch line. Similar lines shall be drawn 10m before and 10m after the scratch line to denote the take-over zone. All take-over procedures shall be completed within this zone.

The Start

6. The races shall be started by the firing of a gun. The commands and procedure for races longer than 400m shall be used (Rule 162.3). In races which include a large number of athletes, a five-minute warning before the start of the race should be given, with additional warnings if required.

Safety and Medical

7. (a) Organising Committees of Road Races shall ensure the safety of athletes and officials. In competitions held under Rules 1.1(a), (b), (c) and (f), the Organising Committee shall ensure that the roads used for the competition are closed to motorised traffic in all directions.
- (b) A hands-on medical examination during the progress of an event by the official medical staff appointed by the Organising Committee and identified by armbands, vests or similar distinctive apparel shall not be considered assistance.
- (c) An athlete shall retire at once from the race if ordered to do so by the Medical Delegate or a member of the official

medical staff.

Drinking/Sponging and Refreshment Stations

8. (a) Water and other suitable refreshments shall be available at the start and finish of all races.
- (b) For all events up to and including 10km, drinking/sponging shall be provided at suitable intervals of approximately 2-3km if weather conditions warrant such provision.
- (c) For all events longer than 10km, refreshment stations shall be provided at approximately every 5km. In addition, drinking/sponging stations for water only shall be placed approximately midway between the refreshment stations or more frequently if weather conditions warrant such provision.
- (d) Refreshments, which may be provided either by the Organising Committee or the athlete, shall be made available at the stations nominated by the athlete. They shall be placed so that they are easily accessible to, or may be put by authorised persons into the hands of, the athletes. Refreshments provided by the athletes shall be kept under the supervision of officials designated by the Organising Committee from the time that the refreshments are lodged by the athletes or their representatives.
- (e) An athlete who collects refreshment from a place other than the refreshment stations renders himself liable to disqualification.

Race Conduct

9. In Road Races, an athlete may leave the road or track with the permission and under the supervision of an official, provided that by going off course he does not lessen the distance to be covered.
10. If the Referee is satisfied on the report of a Judge or Umpire or otherwise that an athlete has left the marked course thereby shortening the distance to be covered, he shall be disqualified.

SECTION IX - CROSS-COUNTRY

RULE 250

Cross-Country Races

General

1. There are extreme variations in conditions in which cross country is practised throughout the world and it is difficult to legislate international standardisation of this sport. It must be accepted that the difference between very successful and unsuccessful events often lies in the natural characteristics of the venue and the abilities of the course designer. The following Rules are intended as a guide and incentive to assist countries to develop cross-country running. See also the IAAF Distance Running Manual for detailed organisational information.

Season

2. The cross-country season should normally extend throughout the winter months after the close of the track and field season.

The Course

3.
 - (a) the course must be designed on an open or woodland area, covered as far as possible by grass, with natural obstacles, which can be used by the course designer to build a challenging and interesting race course.
 - (b) The area must be wide enough to accommodate not only the course but also all the necessary facilities.
4. For Championships and international events and, wherever possible, for other competitions:
 - (a) a loop course must be designed, with the loop measuring between 1750m and 2000m. If necessary, a small loop can be added in order to adjust the distances to the required overall distances of the various events, in which case the small loop must be run in the early stages of the event. It is recommended that each long loop should have a total ascent of at least 10m.
 - (b) Existing natural obstacles shall be used if possible. However, very high obstacles should be avoided, as should deep ditches, dangerous ascents/descents, thick undergrowth and, in general, any obstacle which would constitute a difficulty beyond the aim of the competition. It is preferable that

artificial obstacles should not be used but if such use is unavoidable, they should be made to simulate natural obstacles met within open country. In races where there are large numbers of athletes, narrow gaps or other hindrances which would deny the athletes an unhampered run shall be avoided for the first 1500m.

- (c) The crossing of roads or any kind of macadamised surfaces shall be avoided or at least kept to a minimum. When it is impossible to avoid such conditions in one or two areas of the course, the areas must be covered by grass, earth or mats.
 - (d) Apart from the start and finish areas, the course must not contain any other long straight. A "natural", undulating course with smooth curves and short straights, is the most suitable.
5. (a) The course shall be clearly marked with tape on both sides. It is recommended that all along one side of the course a 1m wide corridor, heavily fenced from the outside of the course, shall be installed for the use of organisation officials and media only (obligatory for Championship events). Crucial areas must be heavily fenced; in particular the start area (including the warm-up area and the call room) and finish area (including any mixed zone). Only accredited people will be allowed access to these areas.
- (b) The general public shall only be allowed to cross the course in the early stages of a race at well organised cross-over points, marshalled by stewards.
- (c) It is recommended that, apart from the start and finish areas, the course be a width of five metres, including the obstacle areas.
- (d) If the Referee is satisfied on the report of a Judge or Umpire or otherwise that an athlete has left the marked course thereby shortening the distance to be covered, he shall be disqualified.

Distances

6. Distances at IAAF World Cross-Country Championships should be approximately:

Men	12 km	Women	8 km
Junior Men	8 km	Junior Women	6 km

It is recommended that similar distances be used for other International and National competitions.

The Start

7. The races shall be started by the firing of a gun. The commands and procedure for races longer than 400m shall be used (Rule 162.3).

In international races, five-minute, three-minute and a one-minute warnings shall be given.

Departure boxes shall be provided and the members of each team shall be lined up behind each other at the start of the race.

Drinking/Sponging and Refreshment Stations

8. Water and other suitable refreshments shall be available at the start and finish of all races. For all events, a drinking/sponging station shall be provided every lap, if weather conditions warrant such provision.

Mountain Races

9. Mountain Races take place across country which is mainly off-road and involves considerable amounts of ascent (for mainly uphill races) or ascent/descent (for races which start and finish at the same level).

The recommended approximate distances and total amount of ascent for international races is as follows:

	Mainly Uphill		Start/Finish at Same Level	
	Distance	Ascent	Distance	Ascent
Senior Men	12km	1200m	12km	750m
Senior Women	8km	800m	8km	500m
Junior Men	8km	800m	8km	500m
Junior Women	4km	400m	4km	250m

Not more than 20% of the distance may be on macadamised surface. The courses may be of a lap design.

SECTION X - WORLD RECORDS

RULE 260 World Records

General Conditions

1. The Record shall be made in a bona fide competition which has been duly arranged, advertised and authorised before the day of the event by the Member in whose Country or Territory the event takes place and which has been conducted under the Rules.
2. The athlete achieving the Record must have been eligible to compete under the Rules and must have been under the jurisdiction of a Member of the IAAF.
3. When a World Record is set, the Member in the country where the Record performance was set shall collect together, without delay, all the information required for ratification of the Record by the IAAF. No performance shall be regarded as a World Record until it has been ratified by the IAAF. The Member should immediately inform the IAAF of its intention to submit the performance.
4. The official application form of the IAAF shall be completed and dispatched to the IAAF Office within thirty days. Forms are available, on request, from the IAAF Office, or may be downloaded from the IAAF website. If the application concerns a foreign athlete (or a foreign team), a duplicate of the form shall be sent within the same period to the Member Federation of the athlete (or team).
5. The Member of the country where the Record was set shall send, with the official application form:
 - The printed programme of the competition;
 - The complete results of the event;
 - The photo finish image (see Rule 260.22(c)).
6. Each athlete who sets a World Record must submit to doping control at the end of the event, to be conducted in accordance with the Rules and Procedural Guidelines currently in force. In the case of a Relay Record, all members of the team must be tested.

The sample(s) collected shall be sent for analysis to a WADA-accredited laboratory and the result(s) sent to the IAAF to be added to the other information required by the IAAF for the ratification of the Record. If such testing results in a doping violation, or if such a testing is not conducted, the IAAF shall not

ratify this Record.

7. If an athlete has admitted that, at some time prior to achieving a World Record, he had used or taken advantage of a substance or technique prohibited at that time, then, subject to the advice of the Medical and Anti-Doping Commission, such Record will not continue to be regarded as a World Record by the IAAF.
8. The following categories of World Records are accepted by the IAAF:
 - (a) World Records;
 - (b) World Junior Records;
 - (c) World Indoor Records.
9. For individual events, at least three athletes and for relay events, at least two teams, must be bona fide competitors in the event.
10. The Record shall be better than or equal to the existing World Record for that event, as accepted by the IAAF. If a Record is equalled it shall have the same status as the original Record.
11. Records made in heats or qualifying competitions, in deciding ties, in any event which is subsequently decreed void under the provisions of Rule 125.6, or in individual events in Combined Events competitions, regardless of whether or not the athlete completes the whole Combined Events competition, may be submitted for ratification.
12. The President and the General Secretary of the IAAF together are authorised to recognise World Records. If they are in any doubt whether or not the Record should be accepted, the case shall be referred to the Council for decision.
13. When a World Record has been ratified, the IAAF will so inform the athlete's National Federation, the Federation applying for the Record and the relevant Area Association.
14. The IAAF will supply the official World Record Plaques, for presentation to World Record Holders.
15. If the record is not ratified, the IAAF will give the reasons.
16. The IAAF shall update the official List of World Records every time a new World Record has been ratified. This list shall represent the performances regarded by the IAAF as being, from the date of the list, the best performances yet set by an athlete or team of athletes in each of the recognised events listed in Rules 261, 262, 263.
17. The IAAF shall publish this list on 1 January of each year.

Specific Conditions

18. Except in Road Events:

- (a) The Record shall be made in an athletics facility, which conforms to Rule 140 with or without roof. The construction of the track or runway used shall comply with the specifications in the IAAF Track and Field Facilities Manual.
- (b) For any Record at any distance of 200m or more to be recognised, the track on which it was made shall not exceed 402.3m (440 yards) and the race shall have started on some part of the perimeter. This limitation does not apply to the Steeplechase events where the Water Jump is placed outside a normal 400m track.
- (c) The Record shall be made on a track, the radius of the outside lane of which does not exceed 50m, except where the bend is formed with two different radii, in which case the longer of the two arcs should not account for more than 60° of the 180° turn.
- (d) No performance set by an athlete will be recognised if it has been accomplished during a mixed competition.

19. Records outdoors may be made only on a track which conforms to Rule 160.

20. For World Junior Records, unless the athlete's date of birth has been previously confirmed by IAAF, the first application on behalf of that athlete shall be accompanied by a copy of his passport, birth certificate or similar official document which confirms his date of birth.

21. For World Indoor Records:

- (a) The Record shall have been made in a stadium, which complies with Rule 211 and 213.
- (b) For races of 200m and over, the oval track may not have a nominal length of more than 201.2m (220 yards).

22. For World Records in Running and Race Walking Events, the following conditions for the timing must be respected:

- (a) The Records shall be timed by official Timekeepers, by an approved Fully Automatic Photo Finish System or Transponder System (see Rule 165).
- (b) For races up to and including 400m, only performances timed by an approved Fully Automatic Photo Finish System conforming to the relevant sections of Rule 165 shall be accepted.
- (c) In the case of a Track Record where Fully Automatic Timing

was in operation, the photo finish image and the zero control test must be included in the documentation sent to the IAAF.

- (d) For all records up to and including 200m, information concerning wind speed, measured as indicated in Rule 163.8, 163.9 and 163.10, shall be submitted. If the wind velocity, measured in the direction of running, behind the athlete averages more than 2 metres per second, the Record will not be accepted.
- (e) In a race run in lanes, no Record will be accepted where the athlete has run on or inside the inner curved border of his lane.
- (f) The reaction times, where available, shall be provided in all races where a crouch start and the use of starting blocks are compulsory.

[From 1 January 2009:]

For all Records up to and including 400 metres under Rule 261 and 263, starting blocks linked to an IAAF approved false start control apparatus under Rule 161.2 must have been used and have functioned correctly so that reaction times were obtained.

- 23. For races over multiple distances:
 - (a) A race shall be stated to be over one distance only.
 - (b) However, a race based on the distance covered over a given time may be combined with a race over a fixed distance (for example, 1 Hour and 20,000m - see Rule 164.3).
 - (c) It is permissible for the same athlete to accomplish any number of Records in the same race.
 - (d) It is permissible for several athletes to accomplish different Records in the same race.
 - (e) However, it is not permissible for an athlete to be credited with a Record at a shorter distance if he did not finish the full distance of that race.
- 24. For World Records in Relay Events:
 - (a) They may be made only by a team, all of whose members are citizens of a single Member country. Citizenship may be obtained in any of the ways referred to in Rule 5.
 - (b) A colony which is not a separate Member of the IAAF shall be deemed, for the purpose of this Rule, to be part of its Mother Country.
 - (c) The time set by the first athlete in a relay team may not be submitted as a Record.
- 25. For World Records in Race Walking Events:

At least three Judges who are from either the IAAF Panel of International Race Walking Judges or are Area Level Judges shall be officiating during the competition and shall sign the application form.

26. For World Records in Field Events:
 - (a) The performances shall be measured either by three Field Judges using a calibrated and certified steel tape or bar or by an approved scientific measuring apparatus, the accuracy of which has been confirmed by a qualified Measurement Judge.
 - (b) In the Long Jump and Triple Jump, information concerning wind speed, measured as indicated in Rule 184.4, 184.5 and 184.6 shall be submitted. If the wind velocity measured in the direction of jumping behind the athlete averages more than 2 metres per second, the Record will not be accepted.
 - (c) World Records may be credited for more than one performance in a competition, provided that each Record so recognised shall have been equal or superior to the best previous performance at that moment.
27. For World Records in Combined Events:

The conditions shall have been complied with in each of the individual events, except that, in events where wind velocity is measured, at least one of the following conditions shall be satisfied:

 - (a) The velocity in any individual event shall not exceed plus 4 metres per second.
 - (b) The average velocity (based on the sum of the wind velocities, as measured for each individual event, divided by the number of such events) shall not exceed plus 2 metres per second.
28. For World Records in Road Running Events:
 - (a) The course must be measured by an "A" or "B" grade IAAF/AIMS approved measurer as defined in Rule 117.
 - (b) The start and finish points of a course, measured along a theoretical straight line between them, shall not be further apart than 50% of the race distance.
 - (c) The overall decrease in elevation between the start and finish shall not exceed 1:1000, i.e. 1m per km.
 - (d) Either the course measurer who measured the course or another "A" or "B" grade measurer in possession of the complete measurement data and maps must validate that the course measured was the course run, normally by riding in the lead vehicle.

- (e) The course must be verified (i.e. re-measured) within two weeks preceding the race, on the day of the race or as soon as practical after the race, preferably by a different "A" or "B" grade measurer from the one that did the original measurement.
 - (f) World Records in Road Running Events set at intermediate distances within a race must comply with the conditions set under Rule 260. The intermediate distances must have been measured and marked during the course measurement and must have been verified in accordance with Rule 260.28(e).
 - (g) For the Road Relay, the race shall be run in stages of 5km, 10km, 5km, 10km, 5km, 7.195km. The stages must have been measured and marked during the course measurement with a tolerance of $\pm 1\%$ of the stage distance and must have been verified in accordance with Rule 260.28(e).
29. For World Records in Road Race Walking Events:
- (a) The course must be measured by an "A" or "B" grade IAAF/AIMS approved measurer as defined in Rule 117.
 - (b) The circuit shall be no shorter than 1km and no longer than 2.5km with a possible start and finish in a stadium.
 - (c) Either the course measurer who measured the course or another "A" or "B" grade measurer in possession of the complete measurement data and maps must validate that the course measured was the course covered.
 - (d) The course must be verified (i.e. re-measured) within two weeks preceding the race, on the day of the race or as soon as practical after the race, preferably by a different "A" or "B" grade measurer from the one that did the original measurement.

Note: It is recommended that National Governing Bodies and Area Associations adopt similar rules to the above for the recognition of their own records.

RULE 261

Events for which World Records are Recognised

Fully Automatically Timed performances (F.A.T.)

Hand Timed performances (H.T.)

Men

F.A.T. only: 100m; 200m; 400m;
 110m Hurdles; 400m Hurdles;
 4x100m Relay.

F.A.T. or H.T.: 800m; 1000m; 1500m; 1 Mile; 2000m; 3000m;
5000m; 10,000m; 20,000m; 1 Hour; 25,000m;
30,000m; 3000m Steeplechase.
Relays: 4x200m; 4x400m; 4x800m; 4x1500m.
Road Races: 10km; 15km; 20km; Half Marathon;
25km; 30km; Marathon; 100km; Road Relay
(Marathon distance only).
Race Walking (Track): 20,000m; 30,000m;
50,000m.
Race Walking (Road): 20km; 50km.

Jumps: High Jump; Pole Vault; Long Jump; Triple Jump.

Throws: Shot Put; Discus Throw; Hammer Throw; Javelin
Throw.

Combined Events: Decathlon.

Women

F.A.T. only: 100m; 200m; 400m;
100m Hurdles; 400m Hurdles;
4x100m Relay.

F.A.T. or H.T.: 800m; 1000m; 1500m; 1 Mile; 2000m; 3000m;
5000m; 10,000m; 20,000m; 1 Hour; 25,000m;
30,000m; 3000m Steeplechase.
Relays: 4x200m; 4x400m; 4x800m.
Road Races: 10km; 15km; 20km; Half Marathon;
25km; 30km; Marathon; 100km; Road Relay
(Marathon distance only).
Race Walking (Track): 10,000m; 20,000m.
Race Walking (Road): 20km.

Jumps: High Jump; Pole Vault; Long Jump; Triple Jump.

Throws: Shot Put; Discus Throw; Hammer Throw; Javelin
Throw.

Combined Events: Heptathlon; Decathlon.

RULE 262

Events for which World Junior Records are Recognised

Fully Automatically Timed performances (F.A.T.)

Hand Timed performances (H.T.)

Junior Men

F.A.T. only: 100m; 200m; 400m;
110m Hurdles; 400m Hurdles;
4x100m Relay.

F.A.T.or H.T.: 800m; 1000m; 1500m; 1 Mile; 3000m;
5000m; 10,000m; 3000m Steeplechase;
4x400m Relay.
Race Walking (Track): 10,000m.
Race Walking (Road): 10km*.

Jumps: High Jump; Pole Vault; Long Jump; Triple Jump.

Throws: Shot Put; Discus; Hammer Throw; Javelin Throw.

Combined Events: Decathlon.
*Only ratified if less than 40:00.

Junior Women

F.A.T. only: 100m; 200m; 400m;
100m Hurdles; 400m Hurdles;
4x100m Relay.

F.A.T.or H.T.: 800m; 1000m; 1500m; 1 Mile;
3000m; 5000m; 10,000m; 3000m Steeplechase;
4x400m Relay.
Race Walking (Track): 10,000m.
Race Walking (Road): 10km.

Jumps: High Jump; Pole Vault; Long Jump; Triple Jump.

Throws: Shot Put; Discus Throw; Hammer Throw; Javelin
Throw.

Combined Events: Heptathlon, Decathlon*.
*Only ratified if over 7300 points.

RULE 263

Events for which World Indoor Records are Recognised

Fully Automatically Timed performances (F.A.T.)
Hand Timed performances (H.T.)

Men

F.A.T. only: 50m; 60m; 200m; 400m;
50m Hurdles; 60m Hurdles.

F.A.T. or H.T.: 800m; 1000m; 1500m; 1 Mile; 3000m; 5000m
Relay: 4x200m; 4x400m; 4x800m.
Race Walking: 5000m.
Jumps: High Jump; Pole Vault; Long Jump; Triple Jump.
Throws: Shot Put.
Combined Events: Heptathlon.

Women

F.A.T. only: 50m; 60m; 200m; 400m
50m Hurdles; 60m Hurdles.
F.A.T. or H.T.: 800m; 1000m; 1500m; 1 Mile; 3000m; 5000m.
Relay: 4x200m; 4x400m; 4x800m.
Race Walking: 3000m.
Jumps: High Jump; Pole Vault; Long Jump; Triple Jump.
Throws: Shot Put.
Combined Events: Pentathlon.

IAAF COUNCIL

2007-2011

PRESIDENT

Lamine DIACK (Senegal)

SENIOR VICE PRESIDENT

Sergey BUBKA (Ukraine)

VICE PRESIDENTS

Robert HERSH (USA)

Sebastian COE (Great Britain and N.I.)

Dahlan AL-HAMAD (Qatar)

HONORARY TREASURER

Jean POCZOBUT (France)

INDIVIDUAL MEMBERS

Bill BAILEY (Australia)*

Valentin BALAKHNICHEV (Russia)

Leonard CHUENE (South Africa)

Pauline DAVIS-THOMPSON (Bahamas)

Helmut DIGEL (Germany)

Nawal EL MOUTAWAKEL (Morocco)

Roberto GESTA DE MELO (Brazil)*

Abby HOFFMAN (Canada)

Alberto JUANTORENA DANGER (Cuba)

Hamad KALKABA MALBOUM (Cameroon)*

Suresh KALMADI (India)*

Ilkka KANERVA (Finland)

Isaiah F. KIPLAGAT (Kenya)

Chaoyi LUO (P. R. China)

Neville McCOOK (Jamaica)*

César MORENO BRAVO (Mexico)

José María ODRIÓZOLA (Spain)

Jung-Ki PARK (Korea)

Anna RICCARDI (Italy)

Katsuyuki TANAKA (Japan)

Hansjörg WIRZ (SUI)*

* Area Representative

GENERAL SECRETARY

Pierre WEISS (France)

HONORARY MEMBERS

HONORARY LIFE VICE PRESIDENTS

Hanji AOKI (Japan)
Ollan CASSELL (USA)
Amadeo I.D. FRANCIS (Puerto Rico)
Frederick HOLDER (Great Britain and N.I.)
Arne LJUNGQVIST (Sweden)
Dapeng LOU (P.R. China)
Robert STINSON (Great Britain and N.I.)

HONORARY LIFE PERSONAL MEMBERS

Hassan AGABANI (Sudan)
Eisa AL DASHTI (Kuwait) †
Helio BABO (Brazil)
Pierre DASRIAUX (France)
Juan Manuel DE HOZ (Spain)
Arthur EUSTACE (New Zealand)
Mohamad HASAN (Indonesia)
Carl-Olaf HOMEN (Finland)
Charles MUKORA (Kenya)
Maurice NICHOLAS (Singapore)
Artur TAKAC (Croatia) †
Igor TER-OVANESIAN (Russia)
Jamel SIMOHAMED (Algeria)
Taizo WATANABE (Japan)
Georg WIECZISK (Germany)

IAAF COMMITTEES

2007-2011

TECHNICAL COMMITTEE

Chairperson

Jorge SALCEDO (Portugal)

Members

Gabriel ABAD (Spain)

Filbert BAYI (Tanzania)

Pierre DELACOUR (France)

Julio Roberto GOMEZ (Colombia)

Klaus HARTZ (Germany)

David KATZ (USA)

David LITTLEWOOD (Great Britain and N.I.)

Madeleine MELANDER (Sweden)

Idalberto Jesus MOLINA HERNANDEZ (Cuba)

Anna RICCARDI (Italy)

Brian ROE (Australia)

Yukio SEKI (Japan)

Chunde SHEN (P. R. China)

Fatou SISSOKO (Senegal)

Kari WAUHKONEN (Finland)

Vadim ZELICHENOK (Russia)

Honorary Life Chairperson

Carl-Gustav TOLLEMAR (Sweden)

WOMEN'S COMMITTEE

Chairperson

Claire CHEHAB (Lebanon)

Members

Yuko ARIMORI (Japan)

Zhanna BLOCK (Ukraine)

Hassiba BOULMERKA (Algeria)

Maria Caridad COLON RUENES (Cuba)

Heike DRECHSLER (Germany)

Eleonor FROELICH (Chile)

Grace JACKSON (Jamaica)

Dobromir KARAMARINOV (Bulgaria)

Glynis NUNN-CEARNS (Australia)

Irina PRIVALOVA (Russia)

Mourad SNOUSSI (Tunisia)

Gabriela SZABO (Romania)

Honorary Life Chairperson

Ilse BECHTHOLD (Germany)

RACE WALKING COMMITTEE

Chairperson

Maurizio DAMILANO (Italy)

Members

Khaled AMARA (Tunisia)

Robert BOWMAN (USA)

Sari ESSAYAH (Finland)

Fumio IMAMURA (Japan)

Viacheslav KRASNOV (Russia)

Peter MARLOW (Great Britain and N.I.)

Fausto MENDOZA CAJAS (Ecuador)

Gabriel ROLDAN OLVERA (Mexico)

Luis SALADIE (Spain)

Jane SAVILLE (Australia)

SHANDE Yang (P. R. CHINA)

CROSS-COUNTRY COMMITTEE

Chairperson

Otto KLAPPERT (Germany)

Members

Beatrice AYIKORU (Uganda)
David BEDFORD (Great Britain and N.I.)
Carlos CARDOSO (Portugal)
Siddig IBRAHIM (Sudan)
Luis Miguel LANDA (Spain)
Anne LORD (Australia)
Massimo MAGNANI (Italy)
David OKEYO (Kenya)
Marcos OVIEDO (Venezuela)
Keisuke SAWAKI (Japan)
Thelma WRIGHT (Canada)

MASTERS' COMMITTEE

Chairperson

Cesar MORENO BRAVO (Mexico)

Members

Jim BLAIR (New Zealand)
Bridget CUSHEN (Great Britain and N.I.)
Danny DANIELS (Canada)
Jorge DE LA CANALE (Argentina)
Leonie Paulette ETONG (Cameroon)
Rex HARVEY (USA)
Marina HOERNECKE-GIL (Spain)
Pierluigi MIGLIORINI (Italy)
Vadim MARSHEV (Russia)
Dieter MASSIN (Germany)
Shigenobu MUROFUSHI (Japan)
Dawei WANG (P. R. China)

MEMBER FEDERATIONS

Official abbreviations

AFGHANISTAN (**AFG**)
ALBANIA (**ALB**)
ALGERIA (**ALG**)
AMERICAN SAMOA (**ASA**)
ANDORRA (**AND**)
ANGOLA (**ANG**)
ANGUILLA (**AIA**)
ANTIGUA AND BARBUDA (**ANT**)
ARGENTINA (**ARG**)
ARMENIA (**ARM**)
ARUBA (**ARU**)
AUSTRALIA (**AUS**)
AUSTRIA (**AUT**)
AZERBAIJAN (**AZE**)

BAHAMAS (**BAH**)
BAHRAIN (**BRN**)
BANGLADESH (**BAN**)
BARBADOS (**BAR**)
BELARUS (**BLR**)
BELGIUM (**BEL**)
BELIZE (**BIZ**)
BENIN (**BEN**)
BERMUDA (**BER**)
BHUTAN (**BHU**)
BOLIVIA (**BOL**)
BOSNIA AND HERZEGOVINA (**BIH**)
BOTSWANA (**BOT**)
BRAZIL (**BRA**)
BRITISH VIRGIN ISLANDS (**IVB**)
BRUNEI (**BRU**)
BULGARIA (**BUL**)
BURKINA FASO (**BUR**)
BURUNDI (**BDI**)

CAMBODIA (**CAM**)
CAMEROON (**CMR**)
CANADA (**CAN**)
CAPE VERDE ISLANDS (**CPV**)
CAYMAN ISLANDS (**CAY**)
CENTRAL AFRICAN
REPUBLIC (**CAF**)
CHAD (**CHA**)
CHILE (**CHI**)
CHINA (People's Republic of)
(**CHN**)
COLOMBIA (**COL**)
COMOROS (**COM**)
CONGO (**CGO**)
CONGO (Dem. Rep. of) (**COD**)
COOK ISLANDS (**COK**)
COSTA RICA (**CRC**)
CROATIA (**CRO**)
CUBA (**CUB**)
CYPRUS (**CYP**)
CZECH REPUBLIC (**CZE**)

DENMARK (**DEN**)
DJIBOUTI (**DJI**)
DOMINICA (**DMA**)
DOMINICAN REPUBLIC (**DOM**)

ECUADOR (**ECU**)
EAST TIMOR (**TLS**)
EGYPT (**EGY**)
EQUATORIAL GUINEA (**GEQ**)
ERITREA (**ERI**)
ESTONIA (**EST**)
ETHIOPIA (**ETH**)

FIJI (**FIJ**)
FINLAND (**FIN**)
FRANCE (**FRA**)
FRENCH POLYNESIA (**PYF**)

GABON (**GAB**)
THE GAMBIA (**GAM**)
GEORGIA (**GEO**)
GERMANY (**GER**)
GHANA (**GHA**)
GIBRALTAR (**GIB**)
GREAT BRITAIN AND
NORTHERN IRELAND (**GBR**)
GREECE (**GRE**)
GRENADA (**GRN**)
GUAM (**GUM**)
GUATEMALA (**GUA**)
GUINEA (**GUI**)
GUINEA-BISSAU (**GBS**)
GUYANA (**GUY**)

HAITI (**HAI**)
HONDURAS (**HON**)
HONG KONG-CHINA (**HKG**)
HUNGARY (**HUN**)

ICELAND (**ISL**)
INDIA (**IND**)
INDONESIA (**INA**)
IRAN (**IRI**)
IRAQ (**IRQ**)
IRELAND (**IRL**)
ISRAEL (**ISR**)
ITALY (**ITA**)
IVORY COAST (**CIV**)

JAMAICA (**JAM**)
JAPAN (**JPN**)
JORDAN (**JOR**)

KAZAKHSTAN (**KAZ**)
KENYA (**KEN**)

KIRIBATI (**KIR**)
KOREA (**KOR**)
KOREA (Democratic Republic of)
(**PRK**)
KUWAIT (**KUW**)
KYRGHYZSTAN (**KGZ**)

LAOS (**LAO**)
LATVIA (**LAT**)
LEBANON (**LIB**)
LESOTHO (**LES**)
LIBERIA (**LBR**)
LIBYA (**LBA**)
LIECHTENSTEIN (**LIE**)
LITHUANIA (**LTU**)
LUXEMBOURG (**LUX**)

MACAO (**MAC**)
MACEDONIA (Former Yugoslav
Republic of) (**MKD**)
MADAGASCAR (**MAD**)
MALAWI (**MAW**)
MALAYSIA (**MAS**)
MALDIVES (**MDV**)
MALI (**MLI**)
MALTA (**MLT**)
MARSHALL ISLANDS (**MSH**)
MAURITANIA (**MTN**)
MAURITIUS (**MRI**)
MEXICO (**MEX**)
MICRONESIA (**FSM**)
MOLDOVA (**MDA**)
MONACO (**MON**)
MONGOLIA (**MGL**)
MONTENEGRO (**MNE**)
MONTSERRAT (**MNT**)
MOROCCO (**MAR**)
MOZAMBIQUE (**MOZ**)
MYANMAR (**MYA**)

NAMIBIA (**NAM**)
NAURU (**NRU**)

NEPAL (**NEP**)
NETHERLANDS (**NED**)
NETHERLANDS ANTILLES (**AHO**)
NEW ZEALAND (**NZL**)
NICARAGUA (**NCA**)
NIGER (**NIG**)
NIGERIA (**NGR**)
NORFOLK ISLAND (**NFI**)
NORTHERN MARIANAS
ISLANDS (NMA, **NMI***)
*FROM 1 JAN 2008
NORWAY (**NOR**)

OMAN (**OMA**)

PAKISTAN (**PAK**)
PALAU (**PLW**)
PALESTINE (**PLE**)
PANAMA (**PAN**)
PAPUA NEW GUINEA (**PNG**)
PARAGUAY (**PAR**)
PERU (**PER**)
PHILIPPINES (**PHI**)
POLAND (**POL**)
PORTUGAL (**POR**)
PUERTO RICO (**PUR**)

QATAR (**QAT**)

ROMANIA (**ROM, ROU***)
RUSSIA (**RUS**)
RWANDA (**RWA**)
*FROM 1 JAN 2008

SAINT KITTS AND NEVIS (**SKN**)
SAINT LUCIA (**LCA**)
SAINT VINCENT (**VIN**)
EL SALVADOR (**ESA**)
SAMOA (**SAM**)
SAN MARINO (**SMR**)
SAO TOME E PRINCIPE
(Dem. Rep. Of) (**STP**)
SAUDI ARABIA (**KSA**)

SENEGAL (**SEN**)
SERBIA (**SRB**)
SEYCHELLES (**SEY**)
SIERRA LEONE (**SLE**)
SINGAPORE (**SIN**)
SLOVAK REPUBLIC (**SVK**)
SLOVENIA (**SLO**)
SOLOMON ISLANDS (**SOL**)
SOMALIA (**SOM**)
SOUTH AFRICA (**RSA**)
SPAIN (**ESP**)
SRI LANKA (**SRI**)
SUDAN (**SUD**)
SURINAM (**SUR**)
SWAZILAND (**SWZ**)
SWEDEN (**SWE**)
SWITZERLAND (**SUI**)
SYRIA (**SYR**)

CHINESE TAIPEI (**TPE**)
TAJIKISTAN (**TJK**)
TANZANIA (**TAN**)
THAILAND (**THA**)
TOGO (**TOG**)
TONGA (**TGA**)
TRINIDAD AND TOBAGO (**TRI**)
TUNISIA (**TUN**)
TURKEY (**TUR**)
TURKMENISTAN (**TKM**)
TURKS AND CAICOS ISLANDS (**TKS**)

UGANDA (**UGA**)
UKRAINE (**UKR**)
UNITED ARAB EMIRATES (**UAE**)
UNITED STATES OF
AMERICA (**USA**)
URUGUAY (**URU**)
UZBEKISTAN (**UZB**)

VANUATU (**VAN**)
VENEZUELA (**VEN**)
VIETNAM (**VIE**)
US VIRGIN ISLANDS (**ISV**)

YEMEN (Republic of) (**YEM**)

ZAMBIA (**ZAM**)
ZIMBABWE (**ZIM**)

IAAF PARTNER ORGANISATIONS

**Association of International Marathons and Distance Races
(AIMS)**

Contact / information: Hugh Jones, Secretary, 19 Kelly Street, London
NW1 8PG, UK, Tel: +44 20 7209 3193, aimssec@aol.com

<http://aimsworldrunning.org>

International Association of Ultrarunners (IAU)

Contact / information: Dirk Strumane, President,
dirk.strumane@publink.be

<http://www.iau.org.tw>

IPC Athletics - International Paralympic Committee

The Rules of athletics for athletes with a disability can be downloaded
from the web address below:

Contact / information: IPC Athletics, Adenauerallee 212-214 53113
Bonn, Germany, Tel:+49-228-2097-200 Fax:+49-228-2097-209
athletics@paralympics.org

<http://www.paralympic.org>

World Masters Athletics (WMA)

Contact / information:
info@world-masters-athletics.org

<http://www.world-masters-athletics.org>

World Mountain Running Association (WMRA)

Contact / information: Danny Hughes, President, Hallsteads, Gosforth
Cumbria CA20 1BJ England, Tel./Fax: +44 1 9467 25 366,
dannyhughes@ukonline.co.uk
Bruno Gozzelino, Secretary, bgozzel@libero.it

<http://www.wmra.info>